

HICONICS

MH-BAT Series 100Ah Battery Pack User Manual



Copyright © Hiconics Eco-energy Drive Technology Co., Ltd.
2025. All rights reserved.

No part of this document may be reproduced or transmitted in any form or by any means without prior written consent of Hiconics Eco-energy Drive Technology Co., Ltd.

Trademarks and Permissions

HICONICS and other HICONICS trademarks are the property of Hiconics Eco-energy Drive Technology Co., Ltd. All other trademarks and trade names mentioned in this document are the property of their respective holders.

Notice

The purchased products, services and features are stipulated by the contract made between Hiconics Eco-energy Drive Technology Co., Ltd. and the customer. All or part of the products, services and features described in this document may not be within the purchase scope or the usage scope. Unless otherwise specified in the contract, all statements, information, and recommendations in this document are provided "AS IS" without warranties, guarantees or representations of any kind, either express or implied. The information in this document is subject to change without notice. Every effort has been made in the preparation of this document to ensure accuracy of the contents, but all statements, information, and recommendations in this document do not constitute a warranty of any kind, express or implied.

Version

V1.0-20260214

Contents

1 Product Overview

1.1 Target Audience.....	01
1.2 Symbols On The Type Label.....	01
1.3 Warning Signs.....	02
1.4 Battery Safety Regulations.....	03
1.5 General Precautions.....	03
1.6 Limitation of Liability.....	04
1.7 Handling Heavy Objects Safely.....	05
1.8 Identification.....	05

2. Product Introduction

2.1 System Appearance.....	06
2.2 System Assembly Method.....	08

3 System installation

3.1 Packing List.....	13
3.2 Installation Requirements.....	14
3.3 Structural installation.....	15

4. System Expansion

4.1 Install the base.....	22
4.2 Install the top cover.....	23

5 Emergency Procedures 23

6 Product Protection 24

7. Battery Storage

7.1 Storage Environment Requirements.....	25
7.2 Storage Expiry.....	25

8 Battery Maintenance 26

9 Quality Commitment 27

10 System Power on/off..... 28

11 Display light board definition 31

12 Battery System Parameters..... 32







1. Product Overview

This Manual contains important information regarding the operation of the equipment. Please read carefully and follow the instructions strictly before performing any operation. Failure to do so may result in damage to equipment, personnel, or property. Be sure to keep this Manual for maintenance and repair purposes.

1.1 Target Audience

This Manual is intended for qualified electricians. Tasks described in this Manual should only be performed by qualified electricians.

1.2 Symbols On The Type Label

Symbol	Explanation
	CE marking The battery complies with applicable CE requirements.
	TUV marking
	The battery should be recycled in appropriate facilities in an environmentally safe manner.
	High voltage in the battery poses a risk to life!
	Danger Risk of electric shock!
	Follow the accompanying documents.
	The system should not be disposed of with household waste. Disposal information can be found in the accompanying documentation.



Do not dispose of the system together with household waste. Instead, it should be disposed of in accordance with the regulations on electronic waste disposal applicable to the installation site.



Warning:
Explosive Hazard!



Keep the battery module away from open flames or ignition sources.

1.3 Warning Signs

Warning signs contain important information for safe operation and must not be torn or damaged. Ensure that warning signs are always properly placed. Damaged signs must be replaced immediately.



Danger!

Indicates a hazard with a high level of risk which, if not avoided, will result in death or serious injury.



Warning!

Indicates a hazard with a medium level of risk which, if not avoided, could result in death or serious injury.



Caution

Indicates a hazard with a low level of risk which, if not avoided, could result in minor or moderate injury.



Notice

Indicates actions of which, if not avoided, could result in material damage.

Important Safety Instructions



Danger!

- High voltage in the battery poses a risk to life! All work must be performed by a qualified electrician. This equipment must not be used by children or individuals with physical, sensory, or mental disabilities, or those lacking experience and knowledge, unless they are under supervision or instruction.
- Electric shock hazard!

**Warning!**

- Ensure the input DC voltage is \leq the maximum DC voltage. Overvoltage may cause permanent damage to the system or other components, which will not be covered under warranty!
- Authorized service personnel must disconnect the AC and DC power before attempting any maintenance, cleaning, or working on any circuit connected to the system.
- Do not operate the system while the equipment is running.

**Caution!**

- There is a burn risk due to overheating of external components!The upper part and body of the casing may become hot during operation.During operation, Do not remove the decorative cover.
- Radiation may cause health damage!Do not stay within 20 cm of the battery.

1.4 Battery Safety Regulations

Hazard Information

This product uses lithium iron phosphate batteries and complies with the United Nations recommendations for the transport of dangerous goods, having passed testing and obtained UN38.3 certification. The battery contains chemicals stored in sealed metal casings designed to withstand the temperatures and pressures encountered during normal use. Therefore, there are no physical hazards of fire or explosion, nor chemical hazards of dangerous goods leakage under normal usage conditions.

However, if the product is misused, subjected to fire, mechanical shock, electrical stress, or decomposition, gas release vents will be activated. The outer casing of the battery will be destroyed to the limit, potentially releasing harmful substances.

1.5 General Precautions

**Warning!**

There is a risk of chemical burns from electrolyte or toxic gases. Under normal operation, there will be no electrolyte leakage or toxic gas emissions from the battery pack. However, if the battery pack is damaged or malfunctioning, electrolyte leakage or toxic gas emissions may occur.

- Do not touch the battery with wet hands.
- Do not install or operate the battery in potentially explosive environments or high humidity areas.
- If moisture penetrates the battery (e.g., due to casing rupture), do not install or operate the battery.
- Do not move equipment connected to the battery module. Secure the equipment to prevent tipping.
- The battery pack must be transported by the manufacturer or designated personnel. Precautions should be documented and archived.
- During transportation, a fire extinguisher with a minimum capacity of 2 kg and ABC certification must be carried.
- If necessary, when replacing the battery module, request new hazardous material packaging from the supplier, then repack it and return it to the supplier for recycling.
- If electrolyte comes into contact with skin, immediately rinse with clean water and seek medical attention.
- There is a risk of injury when handling or dropping the equipment. The battery pack is heavy. If the battery is improperly lifted or dropped during transportation, installation or removal, there is a risk of injury.
- Do not smoke inside or near the vehicle during loading or unloading.

1.6 Limitation of Liability

Hiconics shall not be liable for any direct or indirect damage to products or property caused by the following situations:

- Unauthorized modifications, design changes, or part replacements of the product;
- Alteration, modification, or erasure of serial numbers or seals by non-technical personnel;
- Failure to comply with local safety regulations ;
- Failure to follow any/all user manuals, installation guides, and maintenance rules;
- Improper or misuse of the equipment;
- Inadequate ventilation for the equipment;
- Damage during transportation (including paint scratches due to friction within the packaging); claims should be filed immediately with the transportation or insurance company after unloading the container/ packaging and confirming the damage;

- Force majeure (e.g., storms, lightning, fire, etc.);
- Any damage caused by external factors.
- Failure to maintain according to standard maintenance procedures;

1.7 Handling Heavy Objects Safely

- When handling heavy objects, be prepared to bear the weight to avoid being injured or strained by the object.

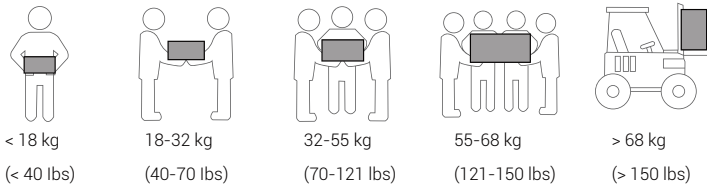

- When multiple people are moving heavy objects simultaneously, consider height and other factors, ensuring proper team coordination and weight distribution.
- When two or more people are moving heavy objects together, one person should act as the leader, guiding the lifting or lowering of the equipment to ensure synchronized movements.
- When manually moving equipment, wear protective gloves, safety shoes, and other safety gear to prevent injuries.
- When manually moving equipment, approach the object, squat down, and use the strength of your legs to lift the object slowly and steadily. Do not use your back, and avoid sudden jerking or twisting movements.
- Do not lift heavy objects directly to waist height; instead, place them on a workbench or an appropriate height, adjust your grip, and then lift.
- Heavy objects must be carried steadily and balanced; the movement should be slow and uniform, and positioning should be smooth and gradual to avoid impacts or drops that could damage the equipment's surface or components, including cables.

1.8 Identification

Manufacturer Information

Name: Hiconics Eco-energy Drive Technology Co., Ltd.
 Add: No.3 Boxing 2nd Road, Economic and Technological Development Zone, 100176, Beijing, P.R. China
 Tel: +61 1300 457 098
 Email: solar_service_au@midea.com
 web: www.hiconics.com

Importer Information

Name: Midea Electronics Australia Co Pty Ltd
 Add: Suite Level 12, 600 St Kilda Road Melbourne VIC 3004, Australia
 TEL: +61 1800 511 806
 Email: info@sunovagroup.com.au
 web: www.midea.com/au

2 Product Introduction

2.1 System Appearance

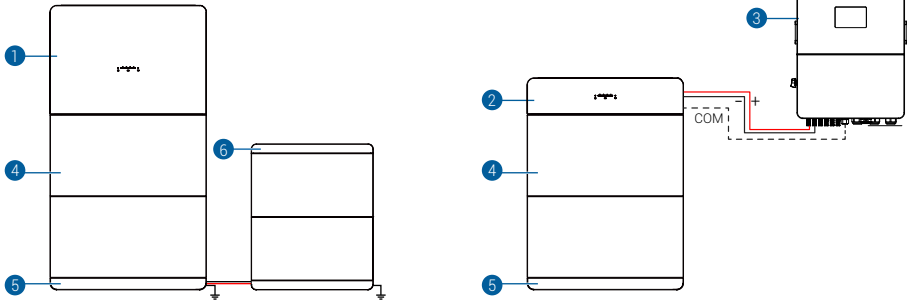

NO.	Name	Model
1	Inverter	3-8kW Europe: MH-HYIV3.0-SHE MH-HYIV3.68-SHE MH-HYIV3.8-SHE MH-HYIV4.0-SHE MH-HYIV4.6-SHE MH-HYIV5.0-SHE MH-HYIV6.0-SHE MH-HYIV8.0-SHE MH-HYIV5.0-SHE-BE Australia: MH-HYIV3.0-SHE-AU MH-HYIV3.68-SHE-AU MH-HYIV3.8-SHE-AU MH-HYIV4.0-SHE-AU MH-HYIV4.6-SHE-AU MH-HYIV5.0-SHE-AU MH-HYIV6.0-SHE-AU MH-HYIV8.0-SHE-AU
		10-12kW Europe: MH-HYIV10.0-SHE MH-HYIV12.0-SHE Australia: MH-HYIV10.0-SHE-AU MH-HYIV12.0-SHE-AU
		5-15kW Europe: MH-HYIV6.0-THE MH-HYIV8.0-THE MH-HYIV5.0-THE MH-HYIV12.0-THE MH-HYIV10.0-THE MH-HYIV15.0-THE MH-HYIV10.0-THE-BE Australia: MH-HYIV5.0-THE-AU MH-HYIV6.0-THE-AU MH-HYIV8.0-THE-AU MH-HYIV10.0-THE-AU MH-HYIV12.0-THE-AU MH-HYIV15.0-THE-AU
2	Energy Storage Connection Box	MH-MB1000/50-HP
3	Inverter	15-30kW Europe: MH-HYIV15.0-TH-S4 MH-HYIV20.0-TH MH-HYIV25.0-TH MH-HYIV29.9-TH MH-HYIV30.0-TH Australia: MH-HYIV15.0-TH-S4-AU MH-HYIV20.0-TH-AU MH-HYIV25.0-TH-AU MH-HYIV29.9-TH-AU MH-HYIV30.0-TH-AU

NO.	Name	Model	
4	Battery Pack	MH-BAT5.0-HPE	MH-BAT5.0-HP
5	Base	MH-BASE-S1	MH-BASE-S1-D
6	Top	MH-BOX-S1	

2 Energy Storage Connection Box Introduction

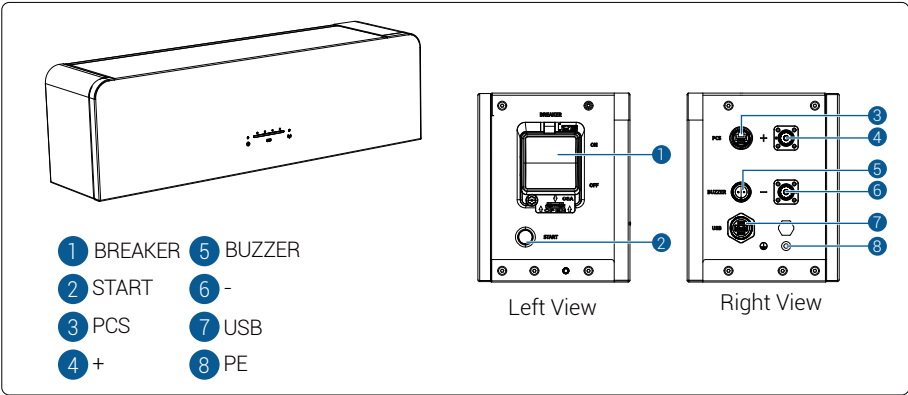

4 Battery Pack Introduction (Air switch version)

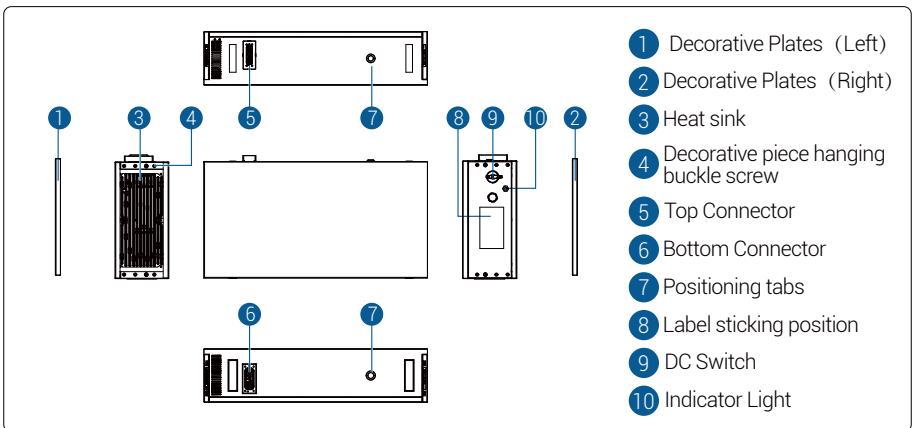

4 Battery Pack Introduction (No air switch version)

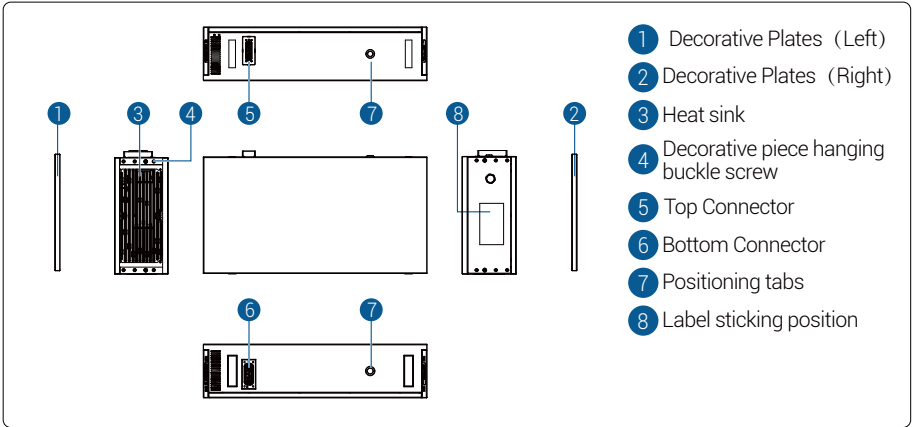

5 Base Introduction

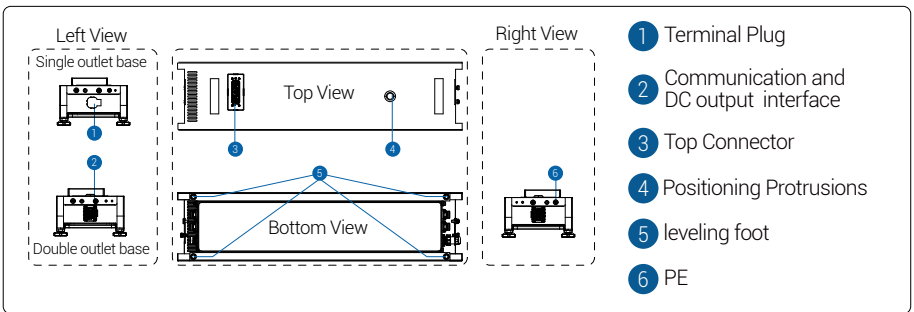

2.2 System Assembly Method

Energy Storage Connection Box dimensions (unit: mm):

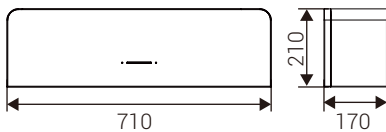

Battery pack dimensions (unit: mm):

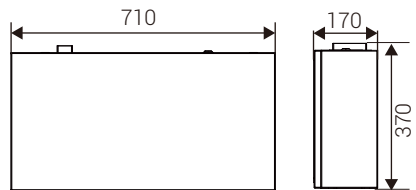

Top dimensions (unit: mm):

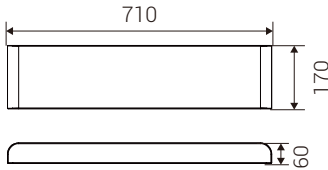

Base dimensions (unit: mm):

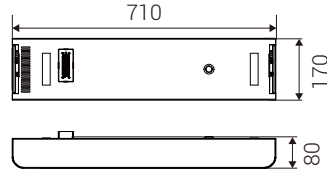

System composition method



Notice

The system can be configured as a single cluster or multiple clusters. Each cluster can accommodate up to 4 PACKs. Up to 4 clusters can be installed. A single system supports up to 12 battery packs.

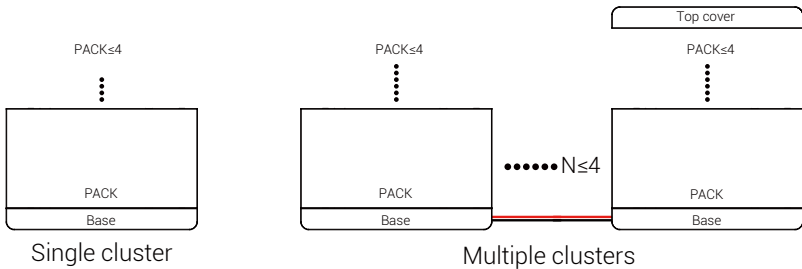

Recommended combination method

Quantity	Capacity	Quantity	Capacity	Quantity	Capacity	Quantity	Capacity	Quantity	Capacity
1	5.12 kWh	2	10.24 kWh	3	15.36 kWh	4	20.48 kWh	5	25.6 kWh
6	30.72 kWh	7	35.84 kWh	8	40.96 kWh	9	46.08 kWh	10	51.2 kWh
11	56.32 kWh	12	61.44 kWh						

Model	Number of system battery packs	Recommended installation configuration form	Recommended cluster number	Recommend the number of packages for each cluster pairing
MH-BAT5.0-HPE	1	1pack+base	1	1
MH-BAT10.0-HPE	2	2pack+base	1	2
MH-BAT15.0-HPE	3	3pack+base	1	3
MH-BAT20.0-HPE	4	4pack+base	1	4
MH-BAT25.0-HPE	5	2pack+base/3pack+base+top	2	2+3
MH-BAT30.0-HPE	6	3pack+base/3pack+base+top	2	3+3
MH-BAT35.0-HPE	7	3pack+base/4pack+base+top	2	3+4
MH-BAT40.0-HPE	8	4pack+base/4pack+base+top	2	4+4
MH-BAT45.0-HPE	9	3pack+base/3pack+base+top/3pack+base+top	3	3+3+3
MH-BAT50.0-HPE	10	3pack+base/3pack+base+top/4pack+base+top	3	3+3+4
MH-BAT55.0-HPE	11	3pack+base/4pack+base+top/4pack+base+top	3	3+4+4
MH-BAT60.0-HPE	12	4pack+base/4pack+base+top/4pack+base+top	3	4+4+4

$PACK \leq 4$

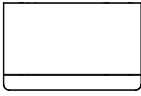

Single cluster
($Base + PACK \leq 4$)

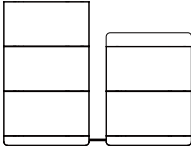

Multiple clusters
($2 * Base + 5 * PACK + 1 * Top$)

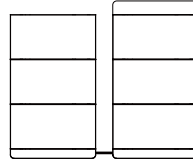

Multiple clusters
($2 * Base + 6 * PACK + 1 * Top$)

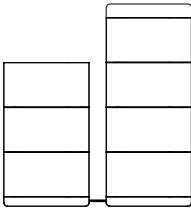

Multiple clusters
($2 * Base + 7 * PACK + 1 * Top$)

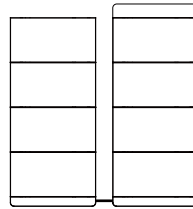

Multiple clusters
($2 * Base + 8 * PACK + 1 * Top$)

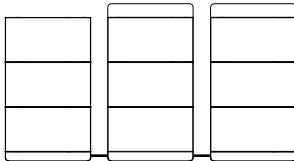

Multiple clusters
($3 * Base + 9 * PACK + 2 * Top$)

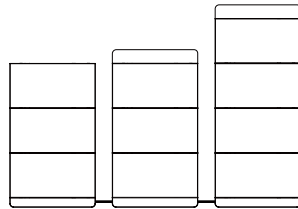

Multiple clusters
($3 * Base + 10 * PACK + 2 * Top$)

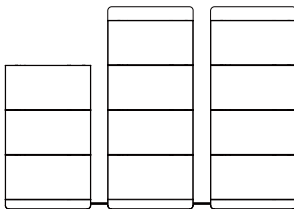

Multiple clusters
($3 * Base + 11 * PACK + 2 * Top$)

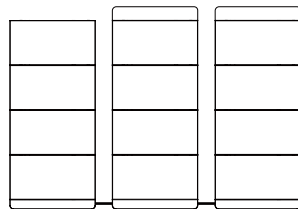

Multiple clusters
($3 * Base + 12 * PACK + 2 * Top$)

Model	Number of system battery packs	Recommended installation configuration form	Recommended cluster number	Recommend the number of packages for each cluster pairing
MH-BAT5.0-HP	1	1pack+base+1Box	1	1
MH-BAT10.0-HP	2	2pack+base+1Box	1	2
MH-BAT15.0-HP	3	3pack+base+1Box	1	3
MH-BAT20.0-HP	4	4pack+base+1Box	1	4
MH-BAT25.0-HP	5	2pack+base/3pack+base+top+1Box	2	2+3
MH-BAT30.0-HP	6	3pack+base/3pack+base+top+1Box	2	3+3
MH-BAT35.0-HP	7	3pack+base/4pack+base+top+1Box	2	3+4
MH-BAT40.0-HP	8	4pack+base/4pack+base+top+1Box	2	4+4
MH-BAT45.0-HP	9	3pack+base/3pack+base+top/3pack+base+top+1Box	3	3+3+3
MH-BAT50.0-HP	10	3pack+base/3pack+base+top/4pack+base+top+1Box	3	3+3+4
MH-BAT55.0-HP	11	3pack+base/4pack+base+top/4pack+base+top+1Box	3	3+4+4
MH-BAT60.0-HP	12	4pack+base/4pack+base+top/4pack+base+top+1Box	3	4+4+4

*BOX Represent Energy Storage Connection Box

PACK≤4

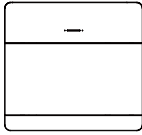

Single cluster
(Base+PACK≤4)

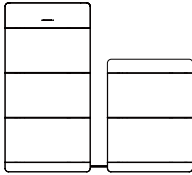

Multiple clusters
(2*Base+5*PACK+1*Top)

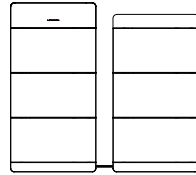

Multiple clusters
(2*Base+6*PACK+1*Top)

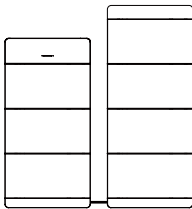

Multiple clusters
(2*Base+7*PACK+1*Top)

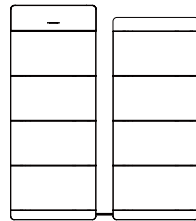

Multiple clusters
(2*Base+8*PACK+1*Top)

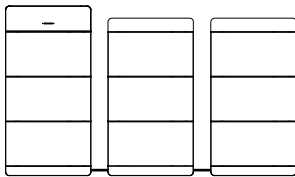

Multiple clusters
(3*Base+9*PACK+2*Top)

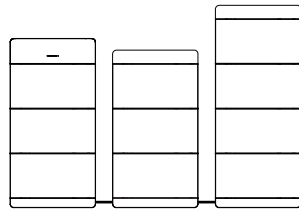

Multiple clusters
(3*Base+10*PACK+2*Top)

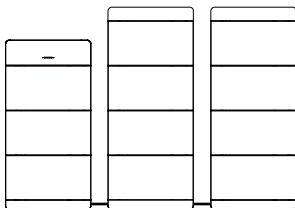

Multiple clusters
(3*Base+11*PACK+2*Top)

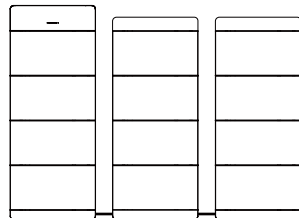

Multiple clusters
(3*Base+12*PACK+2*Top)

3 System installation







Notice





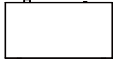

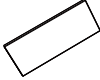
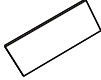

- For Australia market, the installation manual provides a typical and illustrative example of the installation method between battery system and inverter. Please refer to the Recommended Combination Method(P9~P12).
- Before installation, the battery system designers and/or installers are responsible for ensuring the final installation complies with all applicable installation standards, including but not limited to AS/NZS 4777.1, AS/NZS 5139 and AS/NZS 3000.

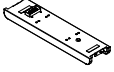
3.1 Packing List

Inverter Packaging Box List					
Inverter*1	M 8 *80*2	CT*1	(Right) Trim Panel*1	(Left) Trim Panel*1	COM1*1
WiFi*1	L Bracket*2	M5*18 Bracket Screws*2	M5X12 Grounding Screw*2	RJ45 Adapter*1	COM 2*1
Backup*1	Grid*1	PV Positive Terminal*N	PV Negative Terminal*N	Quick Installation Manual*1	Certificate of Conformity*1

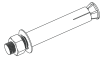
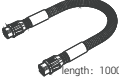
Energy Storage Connection Box & Base Packing List					
1*MH-MB1000/50-HP	1*Decorative panel(Right)	1*Decorative panel(Left)	2*Wall Locking Bracket	3*M5X12	4*M8X80
1*Positive Terminal (Orange) length: 3000mm	1*Negative Terminal (black) length: 3000mm	1*PE length: 3000mm	1*Communication Cable length: 3000mm	3*M 4.8 x 12	1*Base
1*Termination Resistor	1*Terminal	1*PE	6*M 4.8 x 18	1*Floor-Mounted Wall Bracket	2* Carrying handle
2*Fixing piece	1*Certificate of Conformity	1*Quick Installation Manual			

Battery Pack Packing List					
					
1*Battery Pack	2*Fixing piece	4*M4.8X18	1*Decorative panel(Left)	1*Decorative panel(Right)	1*User Manual

Top Cover & Base Packing List					
					
1*Base	2*Fixing piece	1*Floor-Mounted Wall Bracket	14*M 4.8 X18	2* Carrying handle	4*M 8 *80
 length: 1000mm	 length: 1000mm				
1*Terminal	1*PE	1* Top Cover	2*Fixing piece	2*Wall Locking Bracket	

3.2 Installation Requirements

Installation Height Requirements

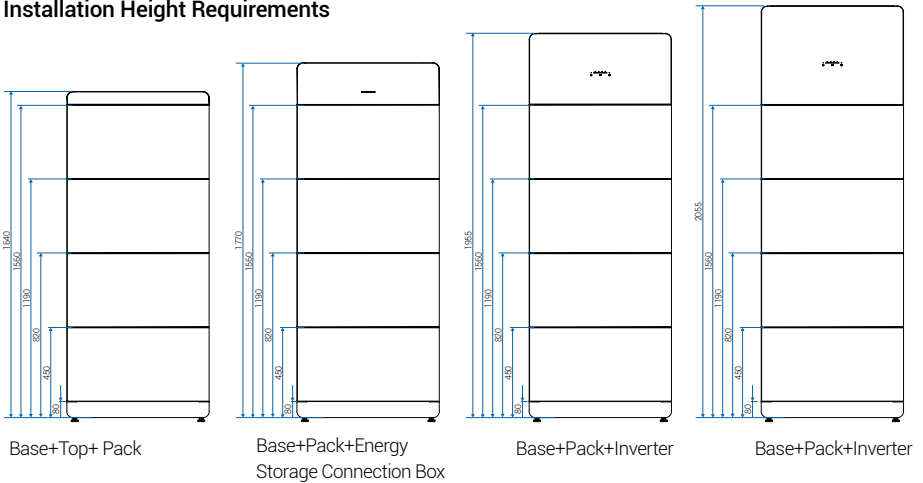

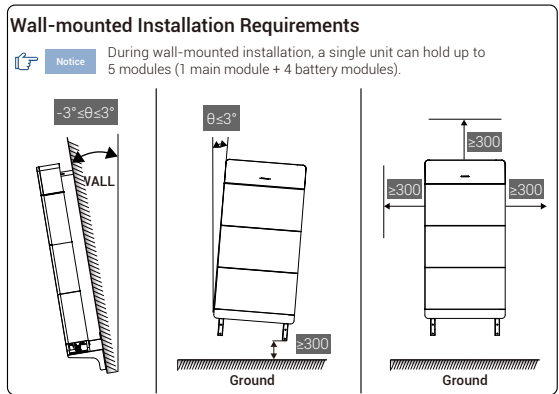
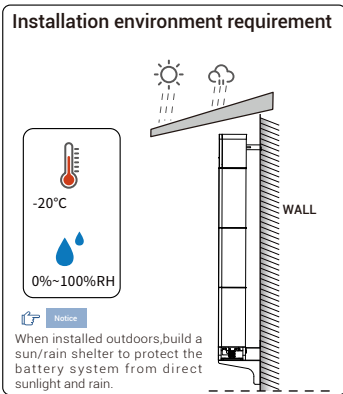
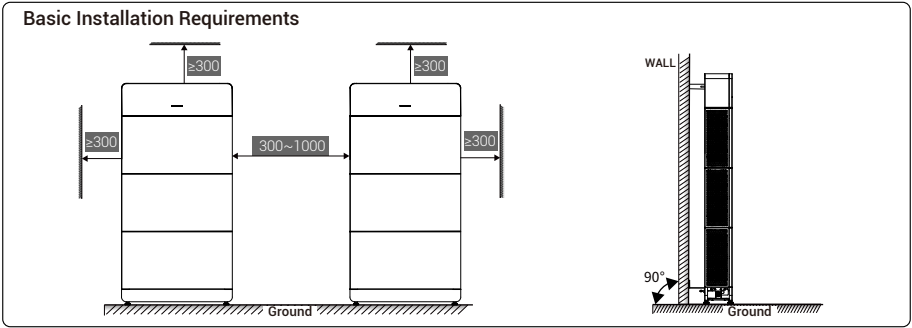

3.3 Structural installation

Installation Tools					
Impact drill($\geq 10\text{mm}$ Drill bit)	Torque screwdriver	Tape measure	Spirit level	Multimeter	Marker pen

Capacity description:

3.3.1 Base installation

01 Base Bracket Installation
(Floor-Mounted Installation).

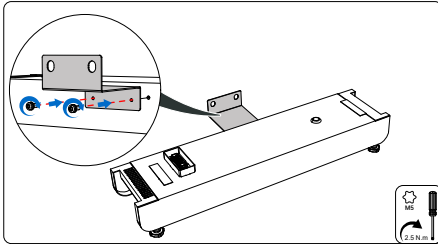

01 Base Bracket Installation
(Wall-Mounted Installation).

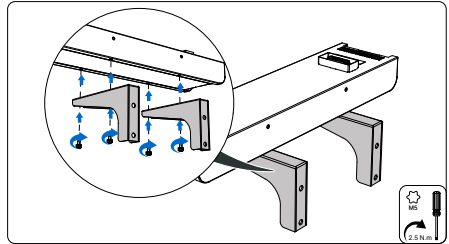

02 Level the Base and Mark Holes (Floor-Mounted Installation).

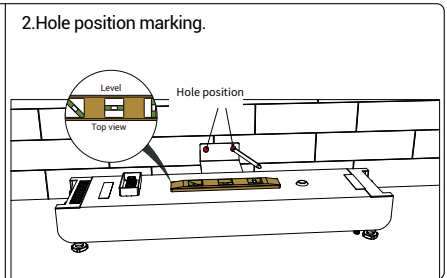
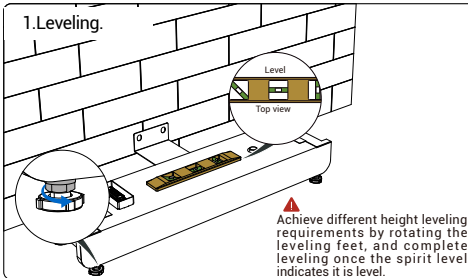

03 Base bracket drilling.

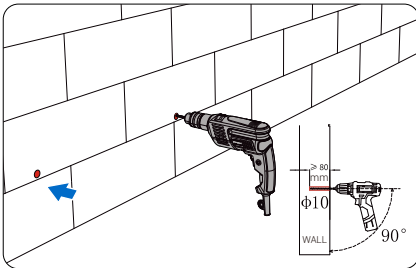

04 Install expansion screws.

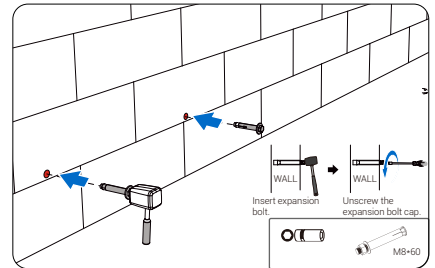

05 Fixing screws, mounting the base (floor mounting).

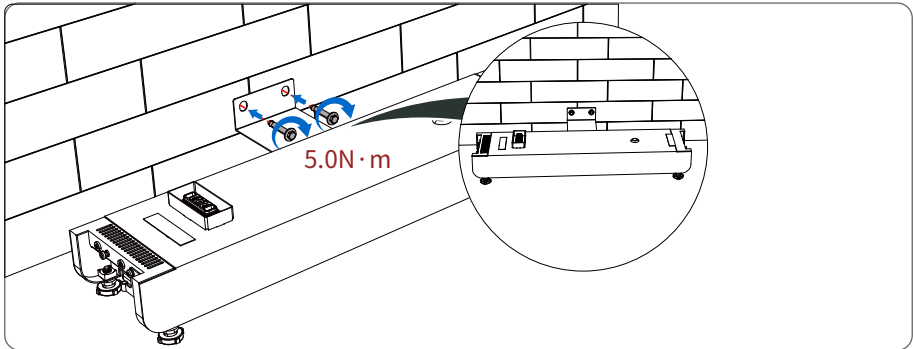

05 Fixing screws, mounting the base (wall mounting).

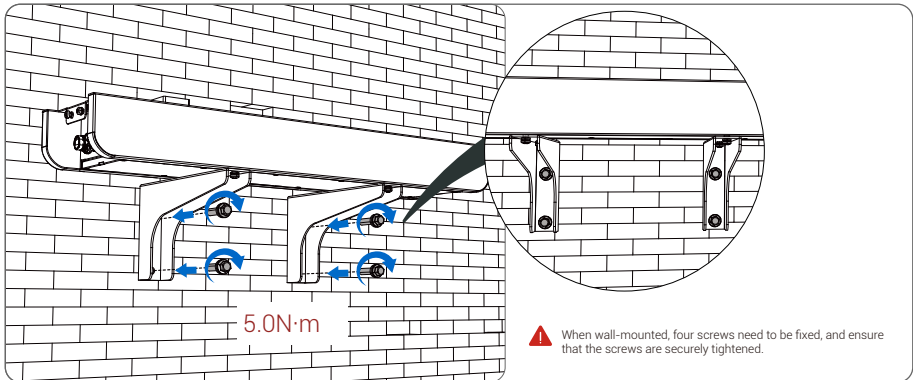

3.3.2 Battery System Installation and Removal



Notice

- 1.If the battery will be idle for a long time, keep the dust cap on, place it in the packaging box, and store it in a ventilated, dry, dust-free location.
 - 2.If the battery has been installed as required, no connector cleaning or maintenance is necessary.
 - 3.Users are strictly prohibited from disassembling the battery pack themselves for repairs; all servicing must be conducted through the designated after-sales service channels.
- Note: there is no onsite maintenance and repair at cell level. All such activities shall be returned to manufacturer.

Battery Port Definitions

Bottom Connector

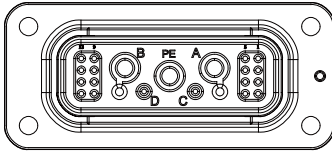

Marking	Definition	Marking	Definition
A	HV+	9	DIO1_EXT
B	HV-	10	COM_GND
PE	PE	11	CANH_BMS
1	DIO2_EXT	12	CANL_BMS
2	COM_GND	13	CANH_D/D
5	CANH_BMS	14	CANL_D/D
6	CANL_BMS	15	SW+
7	CANH_D/D	16	SW-
8	CANL_D/D		

Top Connector

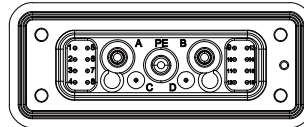

Marking	Definition	Marking	Definition
A	HV+	8	CANL_D/D
B	HV-	9	DIO1_EXT
PE	PE	10	COM_GND
1	DIO2_EXT	11	CANH_BMS
2	COM_GND	12	CANL_BMS
3	CANH_PCS	13	CANH_D/D
4	CANL_PCS	14	CANL_D/D
5	CANH_BMS	15	SW+
6	CANL_BMS	16	SW-
7	CANH_D/D		

Install the battery system

1. Stacked battery pack

2. Fixed battery pack

3. Install left and right decorative panels

4. Battery pack installation completed.

⚠ The battery pack must be secured (after installing the fixing pieces on both sides) before installing the next battery pack.

Remove the battery system

1. Install left and right decorative panels

2. Remove the left and right retaining clips

3. Remove the pack



⚠ During disassembly, remove the battery packs one at a time. Do not begin removing the next battery pack until the previous one has been completely removed.

3.3.3 Energy Storage Battery System and Inverter Installation

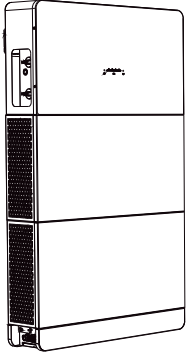
Install the inverter



For detailed installation steps, please refer to the Quick Installation Guide inside the inverter enclosure, or scan the QR code to access the inverter user manual.



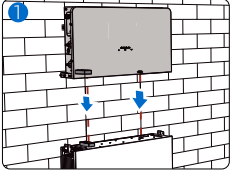

3-8kW 5-15kW

- ① Place the inverter.
- ② Fixing plate on the fixed side and other fastening screws.
- ③ Install the left and right trim panels.

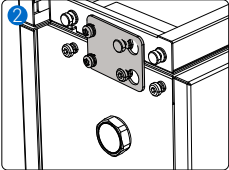

①



②

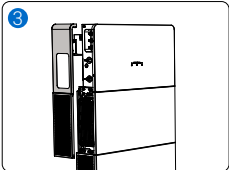

③

Install the Energy Storage Battery System

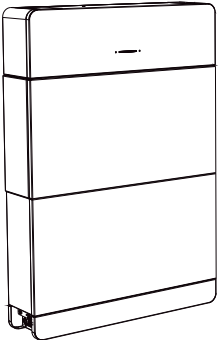

- ① Place the Energy Storage Battery System
- ② Fixing plate on the fixed side and other fastening screws.
- ③ Install the left and right trim panels.

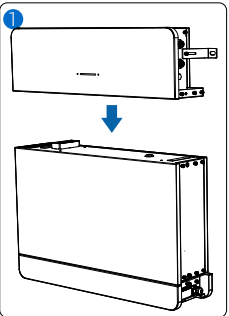

①

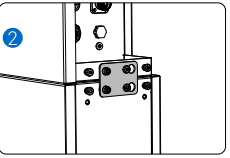

②

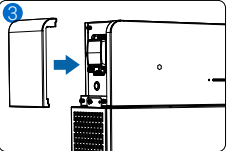

③

For detailed installation steps, please refer to the Quick Installation Guide inside the Energy Storage Battery System enclosure, or scan the QR code to access the Energy Storage Battery System user manual.



User Manual

Install the panels

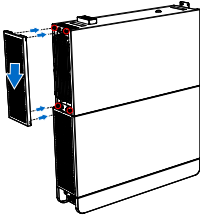

During installation, hook the trim panel onto the screws shown in the illustration.

Remove the trim panel

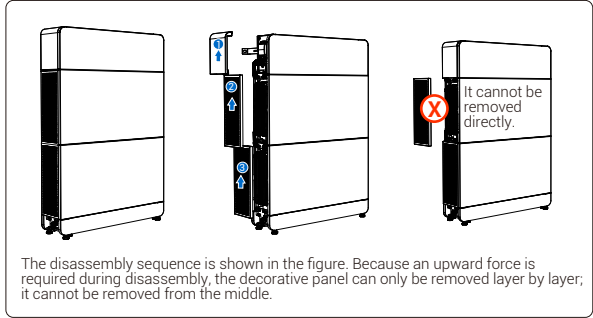

The disassembly sequence is shown in the figure. Because an upward force is required during disassembly, the decorative panel can only be removed layer by layer; it cannot be removed from the middle.

Energy Storage Connection Box wiring harness installation and removal

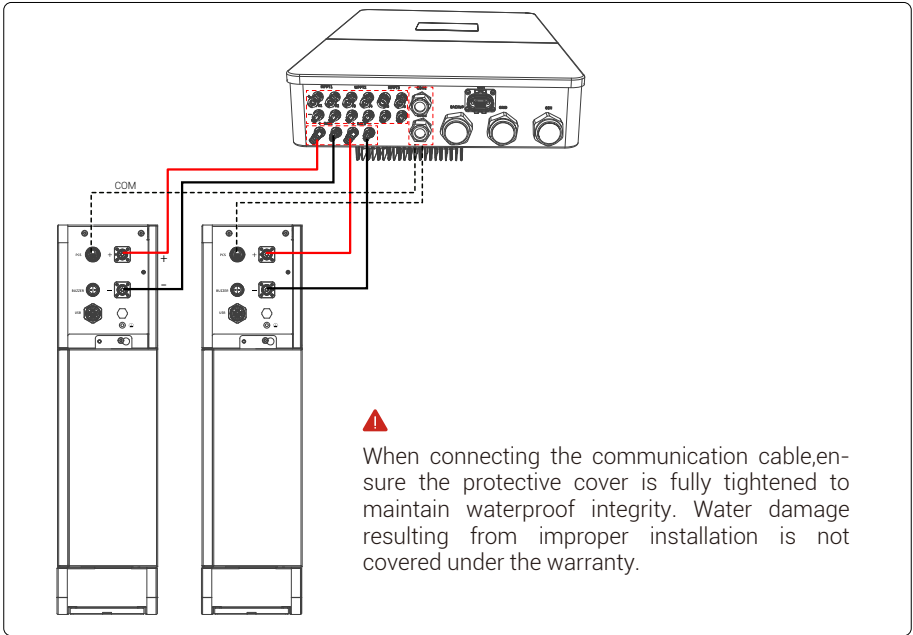

! When connecting the communication cable, ensure the protective cover is fully tightened to maintain waterproof integrity. Water damage resulting from improper installation is not covered under the warranty.

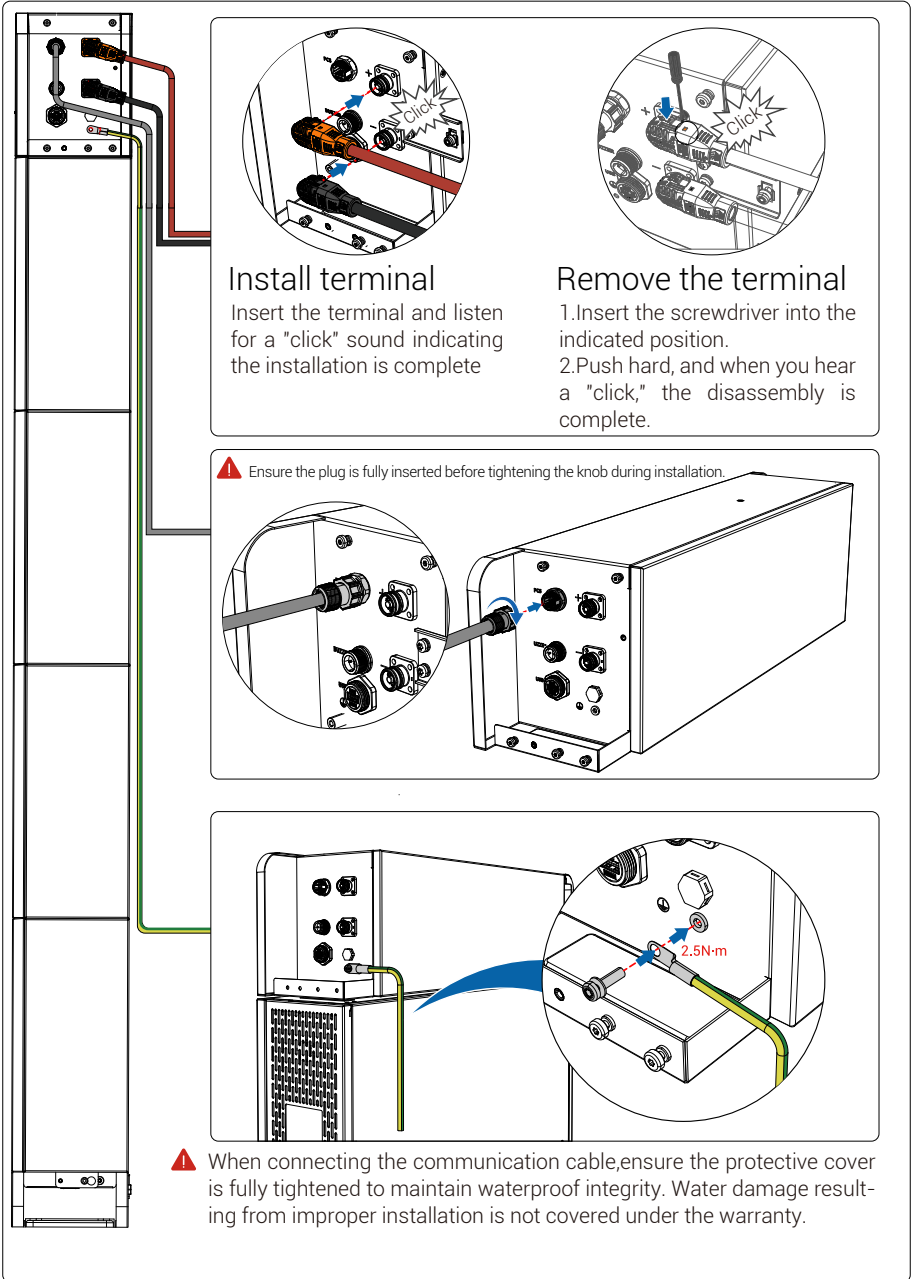

4. System Expansion



Notice

1. During system capacity expansion, use the supplied wiring harnesses; no additional purchases are required. For more installation steps and details, please refer to the quick installation guide included with the Energy Storage Battery System or the inverter, or scan the QR code to access the product user manual.
 2. The connector features a self-locking mechanism and requires a tool to open.

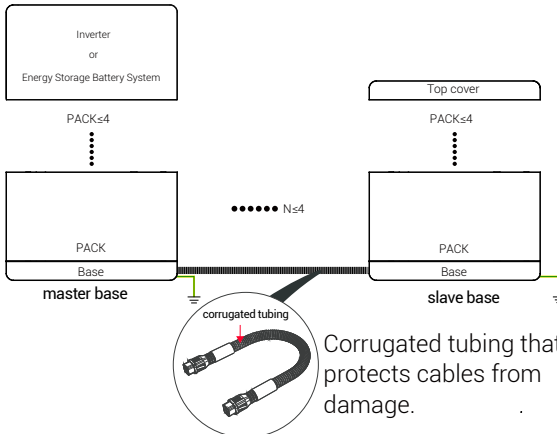

Notice

Interconnected cables between parallel battery packs are protected by DC fuses fitted close to each battery positive and negative terminal. Fuse ratings are selected to match cable ampacity in accordance with AS/NZS 3000 and AS/NZS 5139, clearing fault current before cable damage and isolating faults to prevent cascading failure, complying with AS/NZS 5139, AS/NZS 4777.2 and IEC 62619.

4.1 Install the base

01 Install the wire harness terminals.

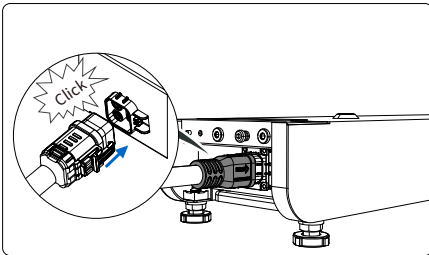

02 Connect the (PE) conductor.

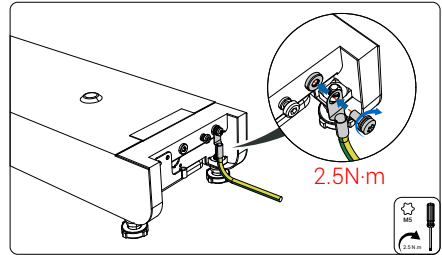

03 Install terminal resistor.

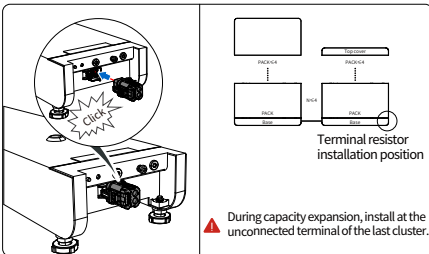

04 Fixed side panel.

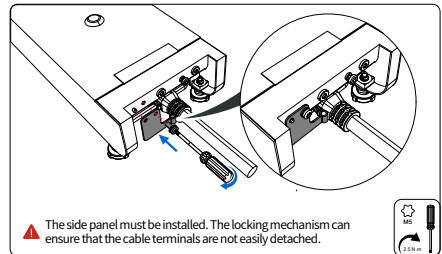

4.2 Install the top cover

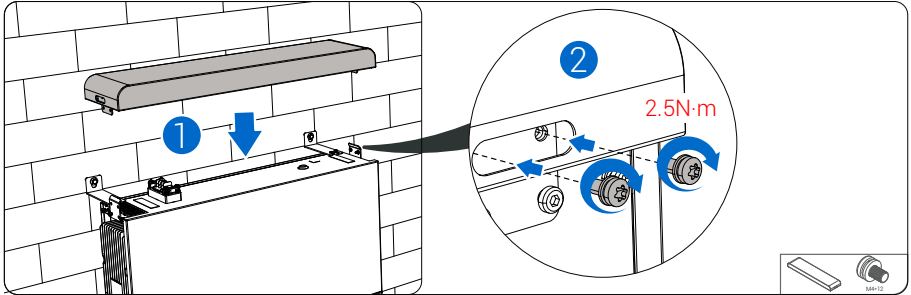

5 Emergency Procedures

Danger

If the battery pack leaks electrolyte, avoid contact with the leaking liquid or gas. If you come into contact with the leaked material, immediately take the following measures:

Inhalation: Leave the contaminated area and seek medical help.

Eye contact: Rinse eyes with tap water for 5 minutes, then seek medical help.

Skin contact: Thoroughly wash the affected area with soap and water, and seek medical help.

Additionally: If vomiting occurs, seek medical help.

Fire

If a fire occurs at the battery pack installation location, follow these procedures:

Fire Extinguishing Medium

Normal operation does not require wearing a mask. Burning batteries cannot be extinguished with a regular fire extinguisher, but require special extinguishers such as Novec1230, FM-200, or CO2 extinguishers. If the fire is not caused by the battery, a regular A, B, or C-class fire extinguisher can be used.

Fire Instructions

- In case of a fire during battery charging, disconnect the battery pack and cut off the charging power circuit breaker under safe conditions.
- If the battery pack has not caught fire, extinguish the fire before the battery pack ignites.
- If the battery pack catches fire, do not attempt to extinguish the fire. Immediately evacuate personnel.



Warning!

When the battery temperature exceeds 150°C, an explosion may occur. Burning battery packs may release toxic gases. Do not approach them.

The effective way to handle the incident

Dry environment: Place the damaged battery in an isolated area and notify the local fire department or service engineer. Wet environment: If any part of the battery, inverter, or wiring is submerged in water, do not touch any of them. Do not reuse batteries that have been exposed to moisture or submerged in water. Contact a service engineer promptly.

6 Product Protection

Radiation Protection

This product uses electronic components and materials that comply with international safety standards and has undergone strict electromagnetic compatibility testing to ensure no harmful radiation is emitted during normal operation.

Vibration Protection

The product design takes into account the potential impact of vibrations on users. By optimizing the structure and selecting high-quality materials, vibrations during operation are minimized.

Do not use this product in poorly ventilated environments. Avoid exposing it to acidic, alkaline, or other corrosive gases. When cleaning or maintaining the product, isolate it from corrosive gases and take appropriate protective measures.

Prevention of Corrosive Liquids

Do not expose this product to acidic, alkaline, or other corrosive liquids. When cleaning or maintaining the product, isolate it from corrosive liquids and take appropriate protective measures. If corrosion is found on the product surface, stop using it immediately and contact the after-sales service center for inspection or replacement.

7 Battery Storage

7.1 Storage Environment Requirements

Store the battery in a dry, ventilated place at room temperature or lower.

Although the battery can be safely used within the temperature range of -20°C to 50°C , it is strongly recommended to avoid storing it at temperatures near the upper or lower limits.

- Storing the battery in a refrigerator may cause internal condensation when the battery is brought to room temperature, which could be hazardous during operation.
- It is best to have a dedicated area for storing lithium-ion batteries. This area must be cool and dry, away from heat sources.
- The area should be free from any flammable materials, such as wooden tables, carpets, or gasoline containers. The ideal surfaces for storing lithium-ion batteries are concrete, metal, or ceramic, or any other non-combustible materials.
- Batteries can be stored in a metal cabinet, such as a chemical storage cabinet, ensuring that the batteries do not come into contact with each other.
- It is recommended to install a fire detector in the storage area.
- Do not leave batteries unattended to avoid damage by others.
- Place an ABC fire extinguisher or CO₂ extinguisher near the storage area.
- Ensure that the work surface is made of non-conductive, non-combustible materials. If you work on conductive materials, cover the surface with insulating material.
- The area should be free from any flammable or combustible materials, such as wooden tables, carpets, or gasoline or other solvents.
- Keep the area free from any sharp objects that could pierce the insulation.
- Keep the area free from any sharp objects that could pierce the insulation.

7.2 Storage Expiry

In principle, it is not recommended to store the battery for long periods. Ensure that the battery is used promptly. Stored batteries should be handled according to the following requirements.

Lithium battery charging interval during storage

Required Storage Temperature	Charging Interval
-20°C~10°C (5%-95%RH)	12 months
10°C~30°C (5%-95%RH)	9 months
30°C~50°C (5%-95%RH)	6months

- If the battery is deformed, damaged, or leaking, regardless of the storage time, it should be discarded immediately.
- The maximum allowable battery energy replenishment period is 3 years, and the replenishment can only be performed up to 3 times. For example, if battery energy is replenished every 6 months, such an action can only be performed up to 3 times, so the battery will not be able to be stored for 3 years.If more than 3 energy replenishments are required or the battery has been stored for more than 3 years, it is recommended to dispose of the battery.
- The SOH of the battery will experience a decrease in capacity after long-term storage. Typically, after being stored for 12 months under recommended storage temperatures, the SOH will irreversibly decrease by 3%–10%. If the discharging and acceptance test is perform in this particular circumstance, the result could be fail because of deteriorating SOH.

8 Battery Maintenance

Servicing of batteries should be performed or supervised by personnel knowledgeable about batteries and the required precautions.

When replacing batteries, replace with the same type and number of batteries or battery packs.

General instructions regarding removal and installation of batteries.

CAUTION: Do not dispose of batteries in a fire. The batteries may explode.

CAUTION: Do not open or damage batteries. Released electrolyte is harmful to the skin and eyes. It may be toxic.

CAUTION: A battery can present a risk of electrical shock and high short-circuit current. The following precautions should be observed when working on batteries:

- Remove watches, rings, or other metal objects.
- Use tools with insulated handles.
- Wear rubber gloves and boots.
- Do not lay tools or metal parts on top of batteries.
- Disconnect charging source prior to connecting or disconnecting battery terminals.
- Determine if battery is inadvertently grounded. If inadvertently grounded, remove source from ground. Contact with any part of a grounded battery can result in electrical shock. The likelihood of such shock can be reduced if such grounds are removed during installation and maintenance (applicable to equipment and remote battery supplies not having a grounded supply circuit).

Precautions

After the equipment stops operating, please pay attention to the following during maintenance:

- Operations and maintenance should comply with relevant safety standards and regulations.
- Disconnect all electrical connections to prevent the equipment from being powered on.
- During maintenance, appropriate protective measures should be taken, such as insulated gloves, shoes, noise-cancelling earplugs, etc. Life is invaluable. Always ensure that no one will be injured.
- In the case of deep discharge (i.e., the battery has not been charged for more than two weeks), the battery must be charged to 30% to 50% SOC.
- Equipment maintenance should only be performed by qualified personnel. Maintenance staff are prohibited from opening any equipment modules on their own.

This Manual is intended as a guide and reference for installation operations. For any matters not specified in this Manual, please contact us promptly.

9 Quality Commitment

During the warranty period, if the product malfunctions, The company or its distributors will provide free service or replace the product with a new one.

Documentation

During the warranty period, customers must provide the product purchase invoice and date. Additionally, the product's trademark must remain intact and legible. Otherwise, Hiconics reserves the right to refuse to fulfill the warranty.

Standard

- Unacceptable product replacements will be handled by Hiconics.
- Customers should allow Hiconics or its distributors reasonable time to repair faulty equipment.

Exemption Clauses

In any of the following cases, Hiconics reserves the right to refuse to fulfill the warranty:

- The warranty period for the whole unit/part has expired;
- The equipment is damaged during transportation;
- Improper installation, reinstallation, or usage of the equipment;
- Equipment used in any harsh environment as described in this Manual;
- Faults or damages caused by installation, maintenance, modification, or disassembly by anyone other than service providers or Hiconics and its authorized partners;
- Faults or damages caused by abnormal use or use not in compliance with Hiconics standards.

Components or Software

- Installation and usage that do not comply with relevant international standards.
- Any damage caused by unexpected natural factors.

For products with faults under the above circumstances, if customers request maintenance, we may provide chargeable maintenance services based on Hiconics' assessment.

10. System Power on/off



Notice

- Ensure the DC switch is in the OFF position during installation.
- For multi-cluster installations, there are no special requirements for the DC switch power-on/off sequence.
- Below we use the Isolation switch version as an example. The No isolation switch version does not have a DC switch on the battery.

Power-on steps

Illustrated sequence **1 → 2 → 3 → 4 → 5**

- Step 1: Open each battery pack's isolation switch; (**There is no such step for the version without protection switch**)
- Step 2: Open the DC protection switch on the PCS;
- Step 3: Open the BAT DC isolating switch on the PCS;
- Step 4: Open the DC button switch on the PCS;
- Step 5: Open the DC button switch on the PCS;

Power-off steps

Illustrated sequence **5 → 4 → 3 → 2 → 1**

- Step 1: Close the DC button switch on the PCS;
- Step 2: Close the DC button switch on the PCS;
- Step 3: Close the BAT DC isolating switch on the PCS;
- Step 4: Close the DC protection switch on the PCS;
- Step 5: Close each battery pack's isolation switch; (**There is no such step for the version without protection switch**)

Power On

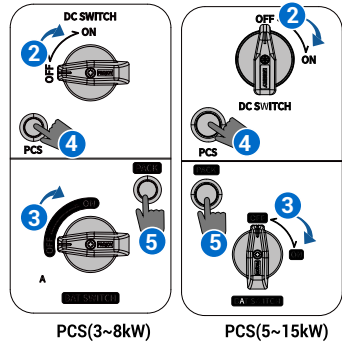
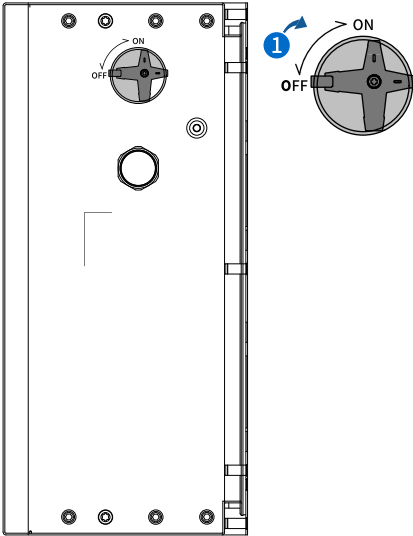

PCS(3~8kW)

PCS(5~15kW)

Green light on: Startup complete



Power Off

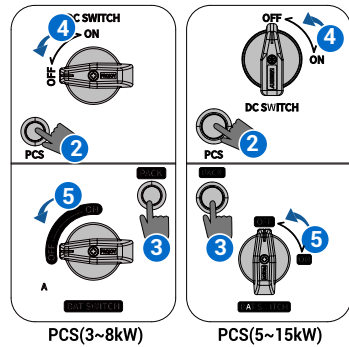
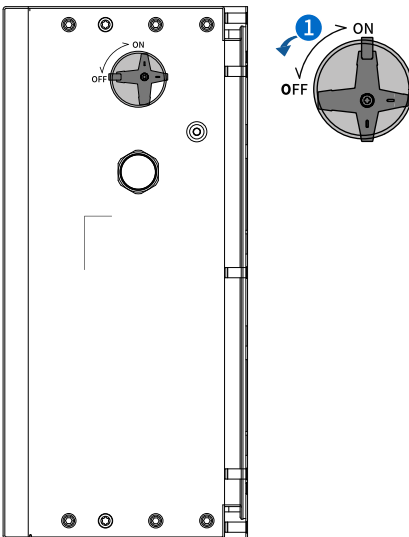

PCS(3~8kW)

PCS(5~15kW)

Light off: Shutdown complete

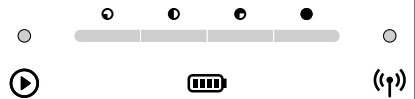

Adapt to high voltage box

The diagram illustrates the electrical connection between PV modules, an inverter, an AC breaker, and the grid. The inverter is connected to an AC breaker, which is connected to the grid. The inverter is also connected to an Energy Storage Connection Box. Detailed insets show the power-on and power-off steps for the inverter and the Energy Storage Connection Box.

Power-on steps

1 → 2 → 3 → 4 → 5 → 6

Power-off steps

6 → 5 → 4 → 3 → 2 → 1









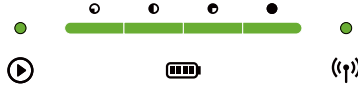

Step 1: Open each battery pack's isolation switch; (There is no such step for the version without protection switch) ;
 Step 2: Open/Close the AC protection switch on the AC output side of the inverter;
 Step 3: Open/Close the DC isolating switch on the inverter;
 Step 4: Open/Close the DC air switch on the Energy Storage Connection Box;
 Step 5: Open/Close the button switch on the Energy Storage Connection Box;
 Step 6: Open/Close the button switch on the inverter;

11 Display light board definition

 **Notice** Battery monitoring is achieved via inverter monitoring APP

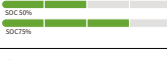
green light on: startup complete



Icon	Meaning	Display	Status	Description
	PCS Status		Green Light On	Inverter Working, Grid-Tied/Off-Grid Mode/Generator Mode Normal
			Green Light Blinking	Inverter in Detection Process/Online Upgrade Mode/Bypass Mode/Standby
			Red Light On	Red Light On: System Fault (Factors that Trigger Machine Stop, Red Light Display)
	Battery Status and Capacity		Light Off	No Battery Connection
			Light Blinks After Capacity	Charging and Current Battery SOC
			Light On After Capacity	Discharging and Remaining SOC
	Communication Connection and Data Transmission		Green Light On	Inverter Communication Module Normal, No Device Connected
			Green light flashing	Green light fast flashing: Communication (When the Bluetooth is connected to the inverter, the indicator light prioritizes indicating "Bluetooth connected: Green light slow flashing") Green light slow flashing: The LED will slow flash after Bluetooth connected

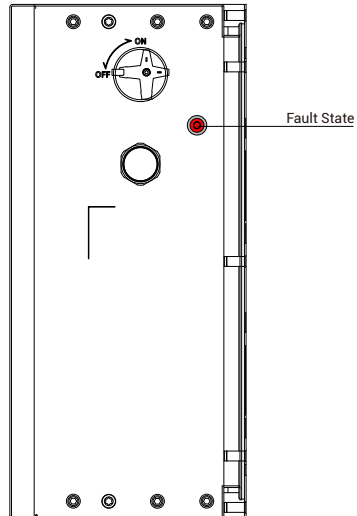
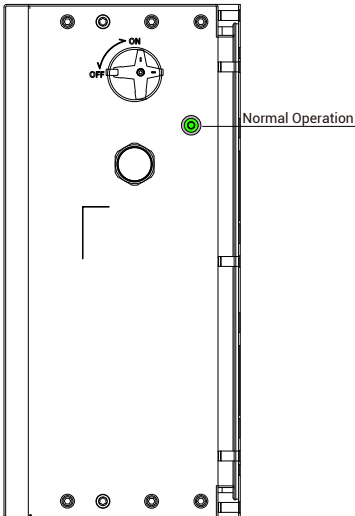

12 Battery System Parameters

Model	MH-BAT5.0-HPE	MH-BAT10.0-HPE	MH-BAT15.0-HPE	MH-BAT20.0-HPE	MH-BAT25.0-HPE	MH-BAT30.0-HPE
	MH-BAT5.0-HP	MH-BAT10.0-HP	MH-BAT15.0-HP	MH-BAT20.0-HP	MH-BAT25.0-HP	MH-BAT30.0-HP
	MH-BAT5.0-HPE-G	MH-BAT10.0-HPE-G	MH-BAT15.0-HPE-G	MH-BAT20.0-HPE-G	MH-BAT25.0-HPE-G	MH-BAT30.0-HPE-G
	MH-BAT5.0-HP-G	MH-BAT10.0-HP-G	MH-BAT15.0-HP-G	MH-BAT20.0-HP-G	MH-BAT25.0-HP-G	MH-BAT30.0-HP-G
Battery Type	LiFePO ₄ (LFP)					
Nominal Voltage (System)	410Vd.c.					
Nominal Voltage (Battery)	51.2 Vd.c.					
Rated Capacity	100Ah	200Ah	300Ah	400Ah	500Ah	600Ah
Rated Energy	5.12kWh	10.24kWh	15.36kWh	20.48kWh	25.6kWh	30.72kWh
Operating Voltage Range (System)	362–464Vd.c.					
Max input/output Power (System)	2.5kW	5.0 kW	7.5kW	10.0kW	12.5kW	15.0kW
Nominal input/output Current (System)	6.1 Ad.c	12.2 Ad.c	18.3 Ad.c	24.4 Ad.c	30.5 Ad.c	36.6 Ad.c
Max input/output Current (System)	6.9 Ad.c.	13.8 Ad.c.	20.7 Ad.c.	27.6 Ad.c.	34.5 Ad.c.	41.4 Ad.c.
Weight	50 kg	100 kg	150 kg	200 kg	250 kg	300 kg
Protective Class	Class I					
Ingress Protection	IP66					
Discharging Temperature Range	-20°C to +50°C					
Charging Temperature Range	-20°C to +50°C					
Battery Designation	5.0:IFpP51/161/119[16S]E/-20+50/95 10.0:IFpP51/161/119[(16S) 2P]E/-20+50/95 15.0:IFpP51/161/119[(16S) 3P]E/-20+50/95 20.0:IFpP51/161/119[(16S) 4P]E/-20+50/95 25.0:IFpP51/161/119[(16S) 5P]E/-20+50/95 30.0:IFpP51/161/119[(16S) 6P]E/-20+50/95					

Model	MH-BAT35.0-HPE	MH-BAT40.0-HPE	MH-BAT45.0-HPE	MH-BAT50.0-HPE	MH-BAT55.0-HPE	MH-BAT60.0-HPE
	MH-BAT35.0-HP	MH-BAT40.0-HP	MH-BAT45.0-HP	MH-BAT50.0-HP	MH-BAT55.0-HP	MH-BAT60.0-HP
	MH-BAT35.0-HPE-G	MH-BAT40.0-HPE-G	MH-BAT45.0-HPE-G	MH-BAT50.0-HPE-G	MH-BAT55.0-HPE-G	MH-BAT60.0-HPE-G
	MH-BAT35.0-HP-G	MH-BAT40.0-HP-G	MH-BAT45.0-HP-G	MH-BAT50.0-HP-G	MH-BAT55.0-HP-G	MH-BAT60.0-HP-G
Battery Type	LiFePO ₄ (LFP)					
Rated Capacity	410Vd.c.					
Rated Energy	51.2 Vd.c.					
Nominal Voltage (System)	700Ah	800Ah	900Ah	1000Ah	1100Ah	1200Ah
Nominal Voltage (Battery)	35.84kWh	40.96kWh	46.08kWh	51.2kWh	56.32kWh	61.44kWh
Operating Voltage Range (System)	362–464Vd.c.					
Max input/output Power (System)	17.5kW	20.0 kW	20.5kW	20.5kW	20.5kW	20.5kW
Nominal input/output Current (System)	42.7 Ad.c	48.8 Ad.c	50.0 Ad.c	50.0 Ad.c	50.0 Ad.c	50.0 Ad.c
Max input/output Current (System)	48.3 Ad.c.	50.0 Ad.c.	50.0 Ad.c.	50.0 Ad.c.	50.0 Ad.c.	50.0 Ad.c.
Weight	350 kg	400 kg	450 kg	500 kg	550 kg	600 kg
Protective Class	Class I					
Ingress Protection	IP66					
Discharging Temperature Range	-20°C to +50°C					
Charging Temperature Range	-20°C to +50°C					
Battery Designation	35.0:IFpP51/161/119[(16S) 7P]E/-20+50/95 40.0:IFpP51/161/119[(16S) 8P]E/-20+50/95 45.0:IFpP51/161/119[(16S) 9P]E/-20+50/95 50.0:IFpP51/161/119[(16S) 10P]E/-20+50/95 55.0:IFpP51/161/119[(16S) 11P]E/-20+50/95 60.0:IFpP51/161/119[(16S) 12P]E/-20+50/95					

*MH-BAT □-HP-G series can be optionally equipped with a high-voltage box.

Warranty Registration Form

For Customer (Compulsory)

Name Country

Phone Number Email

Address

State Zip Code

Product Serial Number

Date of Commissioning

Installation Company Name

Installer Name Electrician License No.

For Installer

Module (If Any)

Module Brand

Module Size(W)

Number of String Number of Panel Per String

Battery (If Any)

Battery Type

Brand

Number of Battery Attached

Date of Delivery Signature

Please visit our warranty website: www.hiconics-global.com

For more detailed warranty terms, please visit Hiconics official Website: www.hiconics-global.com

HICONICS

A member of Midea group

Hiconics Eco-energy Drive Technology Co., Ltd.

No.3 Boxing 2nd Road, Economic and Technological Development Zone,
100176, Beijing, P.R. China

European :

Email: solar_service_eu@midea.com

Australian :

Email: solar_service_au@midea.com Tel: +61 1300 457 098

Global:

Email: solar_service@midea.com

Web: www.hiconics-global.com