



# User Manual

**Powerinfi Single Phase All In One Syetem: 3~8kW**

**Copyright © HICONICS ECO-energy Drive Technology Co., Ltd., All Rights Reserved.**

Without authorization from HICONICS ECO-energy Drive Technology Co., Ltd., no content of this manual may be reproduced, disseminated, or uploaded to public networks or third-party platforms in any form.

**Note:**

Due to product version upgrades or other reasons, the contents of this document will be updated periodically. Unless otherwise specified, the content of this document cannot replace the safety precautions on the product labels; all descriptions in the document are provided as guidance only. All statements, information, etc., contained in this document do not constitute an express or implied warranty.

**Revision Record:**

The change log accumulates the descriptions of each document update. The latest version of the document includes the update content of all previous document versions.

**version:**

20250206-V1.0 Initial release

# Contents

---

## 1. Manual Description

1.1 Scope of Application.....	01
1.2 Product Model and Naming Conventions.....	01
1.3 Target Audience .....	02
1.4 Symbol Explanations .....	02
1.5 Declaration of Conformity for the European Union .....	02

## 2 Safety Precautions

2.1 Symbol Explanation .....	03
2.2 Safety Instructions.....	04
2.3 Handling Precautions .....	07
2.4 Disposal Guidelines .....	08
2.5 After-sales.....	08

## 3 Product Introduction

3.1 Basic Features.....	09
3.2 Supported grid types .....	09
3.3 Operating modes.....	09
3.4 Application Scenario.....	10
3.5 Appearance Introduction.....	12

## 4. Structural Installation

4.1 Packing List.....	17
4.2 Installation Tools .....	18
4.3 Installation Precautions.....	19
4.4 Inverter Only Wall-Mounted Installation.....	21
4.5 Energy Storage System Installation.....	22

## 5. Electrical Installation

5.1 Wiring Requirements.....	28
5.2 Grounding Wire Installation.....	29
5.3 COM1 communication interface connection.....	30
5.4 COM2 Communication Interface Connection.....	31

5.5 GRID Connection.....	34
5.6 PV Installation.....	37
5.7 BACKUP Connection.....	39
5.8 WiFi Module Installation.....	42

## **6 System Operation**

6.1 Device power on/off.....	54
------------------------------	----

## **7 APP Operation**

7.1 APP download and installation.....	58
7.2 Device Configuration.....	62
7.3 Local Bluetooth Configuration.....	65
7.4 Create a Plant.....	66
7.5 Single Power Station Page.....	69
7.6 Adding Devices.....	76
7.7 Device Remote Control.....	77
7.8 <b>Quick Settings</b> .....	80

## **8 Maintenance and Troubleshooting**

8.1 Pre-operation Maintenance.....	86
8.2 Maintenance during operation.....	86

## **9 Fault Information..... 87**

## **10 Packaging, transport, storage..... 94**

Appendix 1 Table of PCS parameters(Europe).....	95
Appendix 2 Table of PCS parameters(Australia).....	97
Appendix 3 Battery Pack Parameter.....	99

# 1. Manual Description

## 1.1 Scope of Application

This manual applies to the 3~8kW household energy storage all-in-one systems of the Powerinfi series. The manual describes precautions for using the product, as well as assembly, commissioning, maintenance, and troubleshooting. Please read this manual carefully before using the product.

## 1.2 Product Model and Naming Conventions

<b>Inverter Model</b>	Europe	Australia
	MEI2-HS3H-AIO	MEI2-HS3H-AIO1
	MEI2-HS3.68H-AIO	MEI2-HS3.68H-AIO1
	MEI2-HS3.8H-AIO	MEI2-HS3.8H-AIO1
	MEI2-HS4H-AIO	MEI2-HS4H-AIO1
	MEI2-HS4.6H-AIO	MEI2-HS4.6H-AIO1
	MEI2-HS5H-AIO	MEI2-HS5H-AIO1
	MEI2-HS5H-AIO2	MEI2-HS6H-AIO1
	MEI2-HS6H-AIO	MEI2-HS8H-AIO1
	MEI2-HS8H-AIO	
<b>Pack</b>	MH-BAT5.0-HPE	

## 1.3 Target Audience

- Installer and maintenance people
- End User

Note: Personnel responsible for installation and maintenance must have undergone rigorous training and obtained the necessary certificates, be familiar with local laws and regulations and relevant standards. Understand the product's working principles, structure, etc., and be aware of various precautions during installation and use.

## 1.4 Symbol Explanations

The following types of safety indication information may appear in this document, as detailed below:



**Danger**

Indicates a high-risk hazard that, if not avoided, could result in death or serious injury.



**Warning**

Indicates a moderate-risk hazard that, if not avoided, could result in death or serious injury.



**Caution**

Indicates a low-risk hazard that, if not avoided, may result in minor or moderate injury.



**Notice**

Indicates actions that, if not avoided, could lead to property damage.

## 1.5 Declaration of Conformity for the European Union

HICONICSICS ECO-ENERGY DRIVE TECHNOLOGY CO., LTD. hereby declares that the equipment described in this document meets the essential requirements and other relevant conditions of the following directives.

### Directive:

Directive 2014/30/EU

(Harmonization of the laws of Member States relating to electrical equipment designed for use within certain voltage limits – short title: Low Voltage Directive)

Directive 2011/65/EU (RoHS)











(Restriction of the Use of Certain Hazardous Substances in Electrical and Electronic Equipment)

You can find the detailed EU Declaration Conformity in the download area:  
([www.HICONICSics-global.com](http://www.HICONICSics-global.com))

## 2 Safety Precautions

### 2.1 Symbol Explanation

This section explains all symbols displayed on the label.

Symbol	Explanation
	CE mark.
	Do not operate this equipment until the AC grid and DC photo-voltaic power supply have been isolated.
	High Temperature Hazard The unit will heat up during operation. Do not direct touch to ensure safety,
	High Voltage Hazard
	Hazard Electrical Shock Hazard!
	Read the User Manual Carefully.
	The unit must not be disposed of with household waste.
	High Voltage Hazard. After the inverter is powered off, residual voltage remains; it must be left for 5 minutes. Perform other operations after 5 minutes.
	RCM The mark indicating product compliance in Australia and New Zealand, showing that the product meets local electromagnetic compatibility and electrical safety standards.
	TUV Mark.

## 2.2 Safety Instructions

### 2.2.1 Important Safety Instructions

**Danger****Danger!**

High voltage inside the inverter can pose a threat to life! All work must be performed by a qualified electrician. Children, persons with physical, sensory or mental disabilities, and those lacking experience and knowledge are prohibited from operating the equipment.

**Caution****Caution!**

Radiation can cause health damage!  
Maintain a distance of more than 20cm from the equipment at all times.

**Notice****Notice!**

Grounding of equipment  
Equipment grounding should comply with local PV grounding requirements.

**Warning****Warning!**

Ensure the input DC voltage  $\leq$  maximum DC voltage. Overvoltage can cause permanent damage to the inverter; such damage is not covered under warranty!

**Warning****Warning!**

Electric shock hazard!

**Warning****Warning!**

Before performing any maintenance, authorize service personnel to disconnect AC and DC power.

**Warning****Warning!**

Do not operate the unit while it is running.

**Warning****Warning!**

The photovoltaic array will generate DC voltage when exposed to sunlight. Do not touch it easily.

**Notice****Notice!**

Inverter protection rating IP66.  
The inverter can only achieve the IP66 protection rating when paired with the battery pack mentioned in the text.

### 2.2.2 General Safety Instructions

- Before use, read the manual carefully to ensure correct and safe operation of the unit. Keep the user manual in a safe place.
- Strictly according to the installation instructions provided in this manual and local laws and regulations during installation.
- The unit must be installed correctly and used under reasonable conditions to qualify for the company's warranty service.
- It is recommended to use the accessories provided with the shipment; using parts that do not meet the requirements may cause damage to the unit or personal injury.
- Ensure that the wiring condition is good and that the cable harness size (diameter, length, etc.) meets the unit requirements.
- Do not disassemble any components of the unit. Please refer to the warranty terms; unauthorized disassembly or repair of the unit may pose certain risks and the unit will no longer be eligible for the warranty service.
- The installation location should be away from damp or corrosive substances, and away from flammable and explosive materials.
- Authorized service person must use insulated tools when installing or operating this unit.
- The PV module should have IEC 61730 Class A certification.
- Do not touch the positive or negative terminals of the PV connection device. Touching both at the same time is strictly prohibited.
- The energy stored in the unit may cause electrical shock hazards; do not operate the device connectors, grid cables, or PV while powered on.
- Cable or photovoltaic generator, etc. After shutting down the photovoltaic, battery, and grid power supply, be sure to wait for 5 minutes to allow the intermediate circuit capacitors to discharge before unplugging the DC, battery connectors, and grid couplers.
- Use a multimeter (with an impedance of at least 1Mohm) to measure the voltage between the DC+ and DC- terminals to ensure the unit has discharged before starting work inside the unit (35VDC).

### 2.2.3 anti-islanding effect

The anti-islanding effect refers to the phenomenon where a grid-connected photovoltaic system continues to supply power to a nearby section of the grid when the grid voltage is lost. This poses a danger to maintenance personnel and the public. The Powerinfi series inverter provides active frequency drift (AFD) to prevent the anti-islanding effect.

## 2.2.4 PE connection and leakage current

- The residual current monitoring unit (RCMU) is integrated into the inverter to prevent the residual current from exceeding the limit. The type A RCD can be connected to the inverter for protection according to the local laws and regulations if required. At the on-grid port, the RCD residual current rating should be 300mA (recommended), or it can be set to other values according to local regulations. At the back-up port., the Maximum RCD residual current rating should be 30mA, or it can be set to other values according to local regulations.

**Danger**

Leakage current!

Connect the grounding device before energizing.

- Improper grounding can lead to personal injury, death, or equipment failure, and increase electromagnetic radiation.
- Ensure the size of the grounding conductor meets safety requirements.

## For use in the UK

- The installation of connecting the device to the power terminals should comply with BS 7671 requirements.
- Do not change any protection settings.
- The user must ensure that the installation, design, and operation of the equipment always comply with the requirements of ESQCR22(1)(a).

## Suitable for Australia and New Zealand

Electrical installation and maintenance should be performed by a licensed electrician and should comply with the national wiring rules of Australia and New Zealand.

## 2.2.5 Battery Safety Instructions

To prevent electric shock and short-circuit current hazards that may be caused by batteries, it is recommended to follow the following preventive measures when replacing batteries:

- Do not wear watches, rings, or other metal items.
- Use insulated tools.
- Wear rubber shoes and gloves.
- Do not place metal tools or similar metal parts on the battery.
- Do not place metal tools or similar metal parts on the battery.
- Before removing the battery connection terminals, disconnect the loads connected to the battery.
- Only personnel with professional knowledge should perform battery maintenance.

If the system detects thermal runaway (electrolyte gas emission; battery combustion, spark formation, and ignition of gas mixtures; battery explosion), it will wirelessly send a thermal runaway signal to the user's alarm system, informing the user that thermal runaway has occurred. The user needs to configure an audible alarm product at home. (The alarm light is red, the sound level of the audible alarm is greater than 85dB but less than 110dB, and the frequency is below 3.5kHz.)



Notice

### 2.3 Handling Precautions

- When moving heavy objects, be prepared to bear the weight to avoid being crushed or injured.

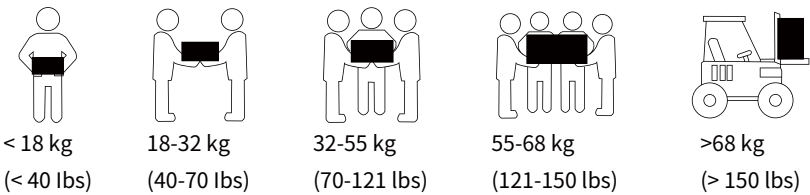

- When multiple people are moving heavy objects together, consider height and other factors, and arrange personnel to ensure even weight distribution.
- When two or more people are moving heavy objects together, one person should direct the operation, lifting or lowering the equipment simultaneously to ensure coordinated movements.
- When handling equipment manually, wear protective gloves, safety shoes, and other protective gear to avoid injury.
- When manually moving the equipment, first approach the object, squat down, and use the strength of your legs to lift, not your back, and slowly and steadily lift the object. Do not suddenly pull or twist your torso.
- Do not quickly raise heavy objects to waist height; instead, place them on a workbench at mid-waist height or an appropriate location, adjust the position of your palms, and then lift them.
- When moving heavy objects, they must be balanced and stable; the movement speed should be even and low; Positioning must be smooth and slow to avoid any shocks or drops, to prevent scratching the surface of the equipment or damaging the components and cables.

## 2.4 Disposal Guidelines

- **Data Erasure:** The product's storage is encrypted. We recommend that customers restore the factory settings before removing the product to clear all user configurations and data.
- **Safe Disposal:** Storage media that cannot be cleared by physical destruction should be disposed of according to environmental regulations.
- **Disconnect the product from the power grid or power source and ensure it is completely shut down.**

## 2.5 After-sales

- **After-sales Service:** Obtain assistance through phone, email, or online customer service.
- **Reporting Channels:** Report safety issues through after-sales service channels.
- **Issue Tracking:** Track the progress of issue resolution through after-sales service channels.

The company shall not be liable for any consequences resulting from any of the following situations:

- **Damage to the equipment caused by natural disasters such as earthquakes, floods, volcanic eruptions, and fires.**
- **Damage to the equipment caused by unauthorized disassembly.**
- **Damage to the equipment caused by using terminals or cable harnesses that do not meet the requirements, or by arbitrarily combining the equipment with other products.**
- **Damage to the equipment caused by unauthorized transportation.**
- **Damage to the equipment caused by improper installation or use not in accordance with the documentation.**

## 3 Product Introduction

### 3.1 Basic Features

The PowerInfi single-phase series is an all-in-one energy exchange system that includes an inverter, battery pack, and base. This system manages energy conversion based on system configuration and energy management system requirements, storing energy in the battery pack or supplying it to the load or grid.

### 3.2 Supported grid types

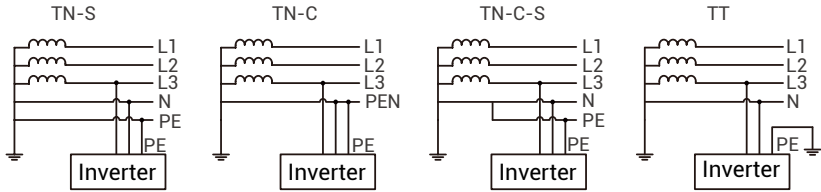

### 3.3 Operating modes

The following are the common modes of the unit. Mode settings need to be configured in the APP; see the APP manual in detail.

#### Selling First Mode:

In Selling First mode, the hybrid inverter is allowed to sell energy to the grid. If the TOU function is activated, the battery's power can also be sold to the grid. This mode allows the hybrid inverter to sell back any excess power produced by the solar panels to the grid. If time of use is active, the battery energy also can be sold into the grid. The PV energy will be used to power the load and charge the battery, and then any excess energy will flow to the grid.

Power source priority for the load is as follows:

01. Solar Panels;
02. Grid;
03. Batteries (until programable % discharge is reached).

#### Zero Export Mode:

Under Zero Export mode, the hybrid inverter can supply energy to local and remote loads (loads between the inverter and CT). If PV and battery energy are insufficient, the grid must provide the additional energy required; in this mode, battery energy does not flow into the grid. A meter or CT is required in this mode.

**Grid Peak Shaving:** When active, grid output power will be limited to the set value. If the load power exceeds the allowed value, PV energy and battery will be used as a supplement. If still unable to meet the load requirement, grid power will increase to fulfill the load needs.

#### Time of Use (TOU):

In the grid-connected state, after enable TOU, you can set different time periods for charging and discharging the battery. When the RTC time of the system is within the time period, and the time period is set to discharge, and the SOC of the battery is higher than the set SOC limit, the battery will be discharged to the SOC limit; when the time period is set to charge, and the SOC of the battery is lower than the set SOC limit, the battery will be charged to the SOC limit.

NOTE: In Selling First mode, the current battery SOC is higher than the set SOC and the battery can be discharged to the grid even during the charging time period.

### 3.4 Application Scenario

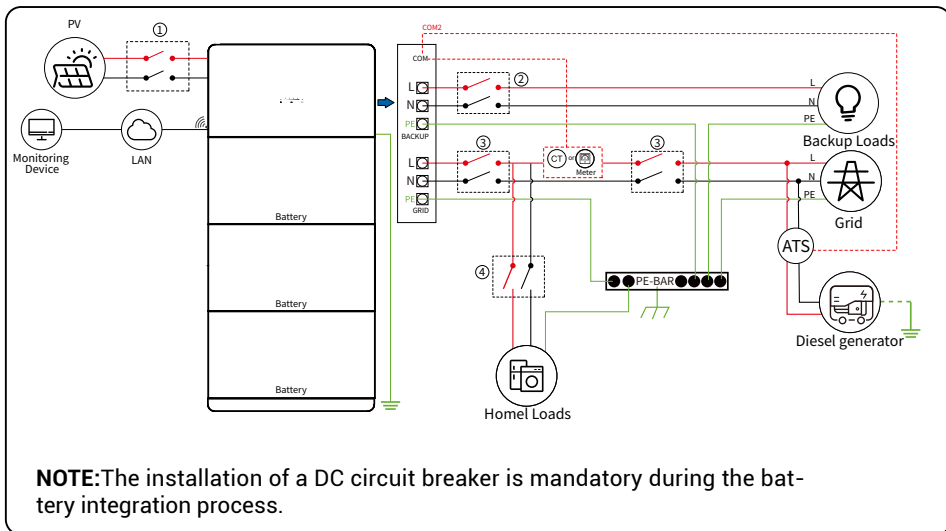

Single system application scenario

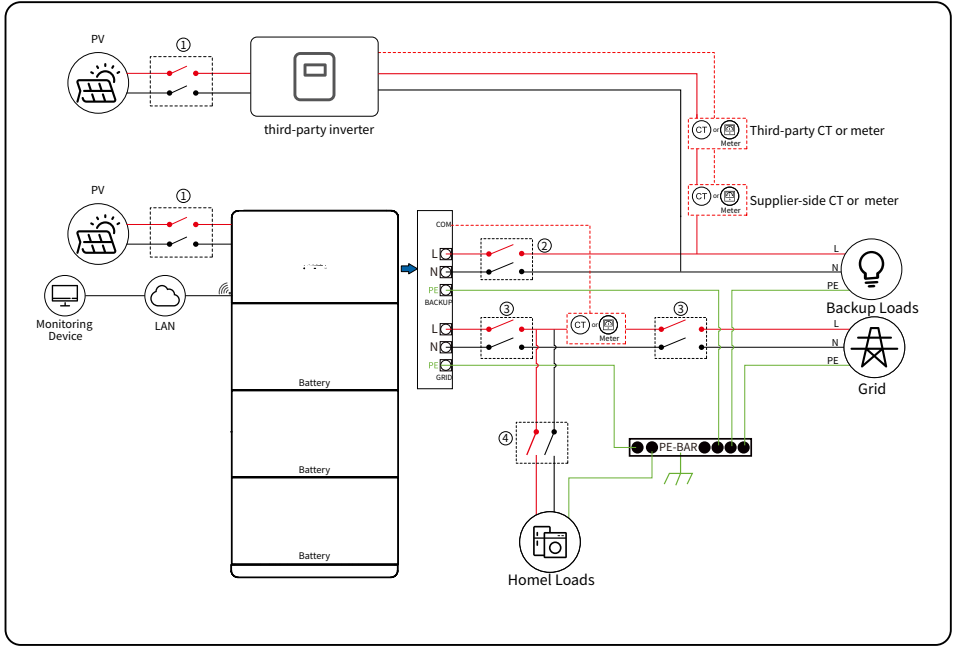

Single system compatible with third-party inverter scenario diagram

**Circuit breaker specifications:**

Model	①	②	③	④
MEI2-HS3H-AIO	≥32A/≥500V DC Breaker	≥40A/≥230V AC Breaker	≥40A/≥230V AC Breaker	≥40A/≥230V AC Breaker
MEI2-HS3.68H-AIO			≥50A/≥230V AC Breaker	≥50A/≥230V AC Breaker
MEI2-HS3.8H-AIO				
MEI2-HS4H-AIO				
MEI2-HS4.6H-AIO				
MEI2-HS5H-AIO				
MEI2-HS5H-AIO2				
MEI2-HS6H-AIO				
MEI2-HS8H-AIO			≥63A/≥230V AC Breaker	≥63A/≥230V AC Breaker

## 3.5 Appearance Introduction

### 3.5.1 System Composition and Dimensions Introduction

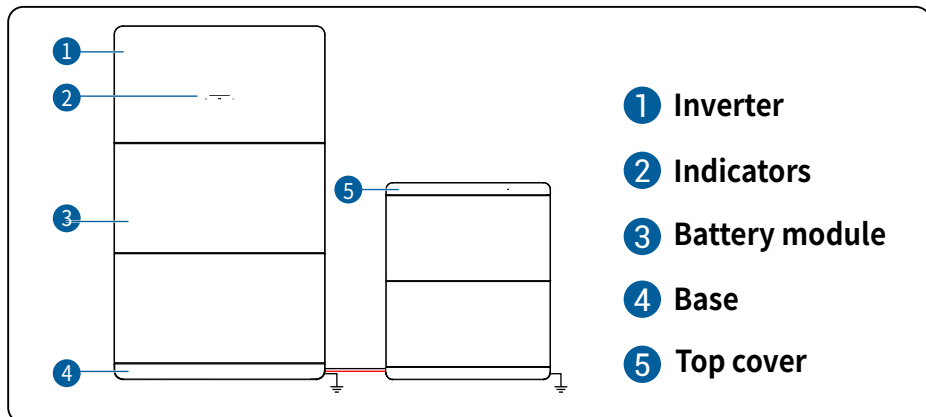

Inverter dimensions (unit: mm):

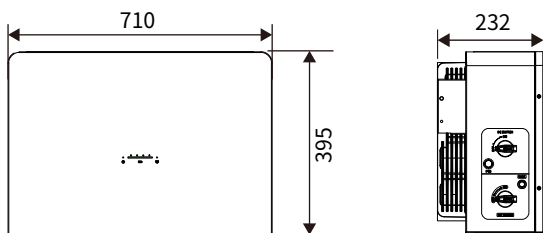

Battery pack dimensions (unit: mm):

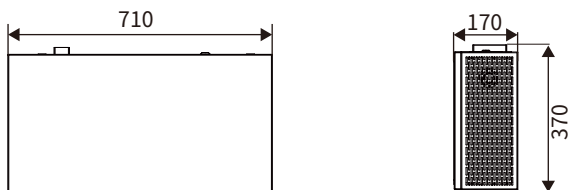

Base dimensions (unit: mm):

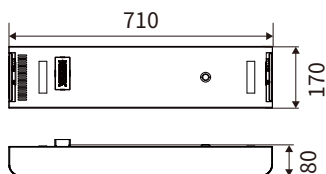

Parallel top cover dimensions (unit: mm):

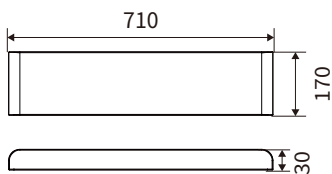

### 3.5.2 Introduction to the Inverter

The inverter is a high-voltage component, sealed by the manufacturer. The inverter can be used alone or in combination with a designated battery pack (model: MH-BAT5.0-HPE), and is fixed to the battery pack with screws. The inverter can only be replaced as a whole and should not be opened. The following is an introduction to the inverter:

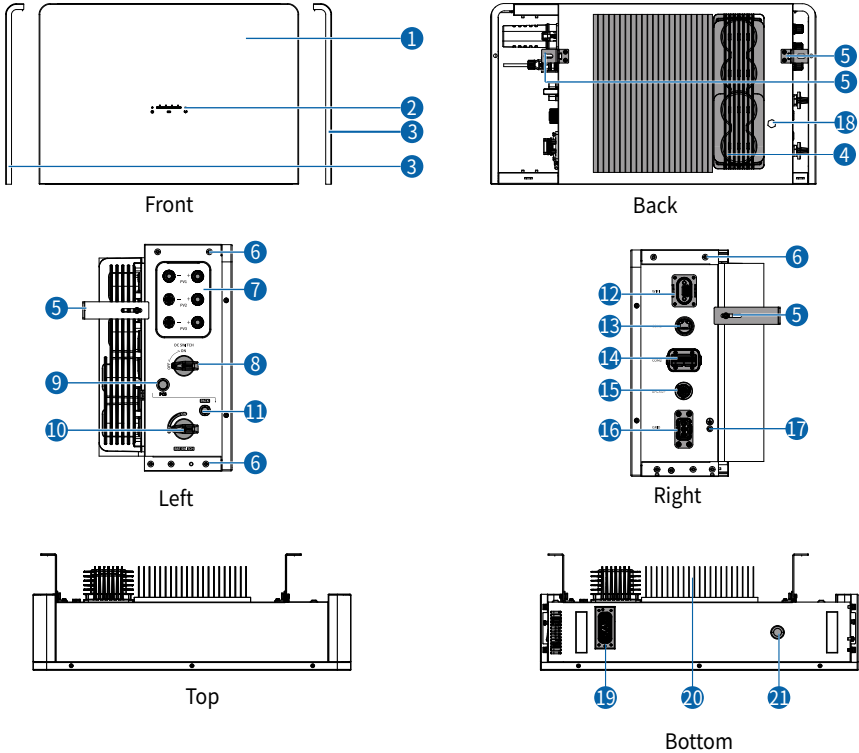

NO.	Definition	Description
1	Front Panel	PCS Front Cover
2	Indicator Light	Display Product Operation Status
3	Side Decorative Panels	Protect Terminal Connections
4	Heat Sink	Helps Cool the Inverter
5	Wall Mounting Plates	Fixes Wall to Inverter
6	Decorative Clip Clips	Fixes Side Decorative Panels
7	PV terminal	PV DC input terminal, connect DC input wire
8	PV SWITCH	DC input switch on and off, Isolate PV array and Inverter
9	PCS button	PCS switch on and off
10	BAT SWITCH	Battery pack switch on and off, Isolated Battery and Inverter
11	PACK button	Battery pack connection and disconnection
12	WiFi	Remote APP communication. The WiFi module is an external component. The Wi-Fi module is external and optional

NO.	Definition	Description
13	COM1	Connect CT or meter
14	COM2	Connector for parallel operation, DI/DO, DRM
15	BACKUP	AC load port
16	GRID	AC grid port
17	PE	Grounding port
18	Venting valve	Pressure relief valve, ensuring the internal pressure of the box does not become too high
19	Bottom connector	Hconnector for plug-in connection with battery pack
20	Heat sink	Helps the inverter to cool down
21	Positioning point	Positions the battery pack and PCS

### 3.5.3 Battery pack

The MH-BAT5.0-HPE is a high-voltage battery that supports the parallel stacking of multiple new and old packs. Communicates with the inverter via its own BMS and manages the charging and discharging of the battery pack.

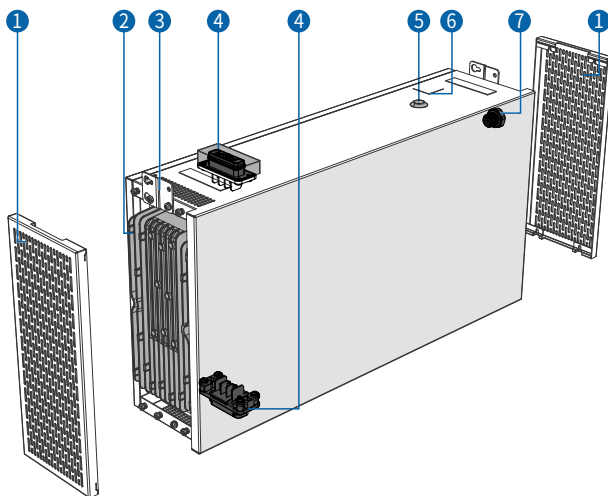

NO.	Definition	Description
1	Side panels	Protect side structural components and prevent touching
2	Heat sink	Aid in battery pack cooling
3	Battery pack securing plate	Secure battery pack to battery pack, battery pack to PCS, and battery pack to base
4	Connector	Connection interface between battery pack and battery pack, battery pack and PCS
5	Positioning boss	Position battery pack, PCS, base, etc.
6	PCS hole marking line	PCS positioning hole auxiliary line
7	Venting valve	Ensure internal cabinet pressure does not become excessive

**Connector definition:**

Bottom Connector

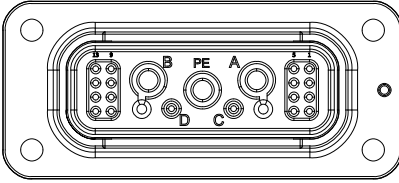

Top Connector

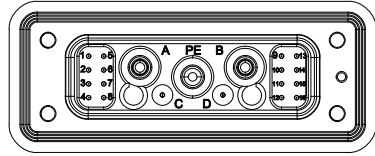

Marking	Definition	Marking	Definition
A	HV+	9	DIO1_EXT
B	HV-	10	COM_GND
PE	PE	11	CANH_BMS
1	DIO2_EXT	12	CANL_BMS
2	COM_GND	13	CANH_D/D
5	CANH_BMS	14	CANL_D/D
6	CANL_BMS	15	SW+
7	CANH_D/D	16	SW-
8	CANL_D/D		

Marking	Definition	Marking	Definition
A	HV+	8	CANL_D/D
B	HV-	9	DIO1_EXT
PE	PE	10	COM_GND
1	DIO1_EXT	11	CANH_BMS
2	COM_GND	12	CANL_BMS
3	CANH_PCS	13	CANH_D/D
4	CANL_PCS	14	CANL_D/D
5	CANH_BMS	15	SW+
6	CANL_BMS	16	SW-
7	CANH_D/D		

**3.5.4 Base Introduction**

The base of the residential energy storage system is used to support the entire system, its Main functions include: Structural Support: Used to support battery modules. Electrical Circuit Closure: There are connectors on the base for connecting to the battery modules, achieving



**Notice**

Closure of the high-voltage circuit and heating circuit. The base is available in single-cluster and multi-cluster versions; if expansion is required, you need to purchase the multi-cluster base accessory kit.

**Base I: Single-Cluster Base**

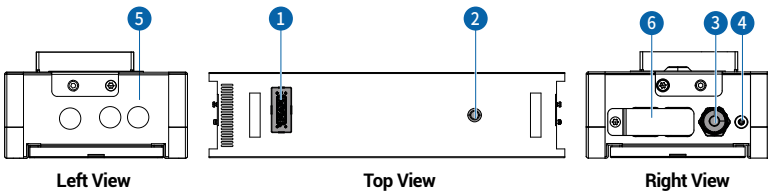

## Base II:Multi-Cluster Base

If expansion is required, Expansion Base II needs to be purchased.

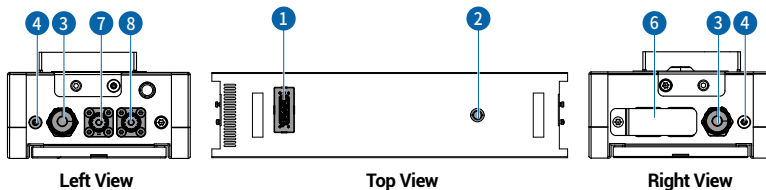

NO.	Definition	NO.	Definition	NO.	Definition
1	Bottom connector	2	Positioning tabs	3	Communication interface
4	PE	5	Lid	6	Baffle
7	DC power supply harness(-)	8	DC power supply harness(+)		

### 3.5.5 Display light board definition

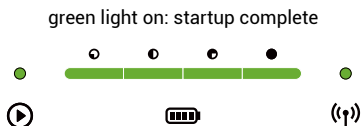









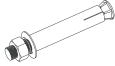





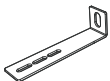



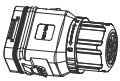

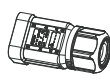

Icon	Meaning	Display	Status	Description
	PCS Status		Green Light On	Inverter Working, Grid-Tied/Off-Grid Mode/Generator Mode Normal
			Green Light Blinking	Inverter in Detection Process/Online Upgrade Mode/Bypass Mode/Standby
			Red Light On	Red Light On: System Fault (Factors that Trigger Machine Stop, Red Light Display)
	Battery Status and Capacity		Light Off	No Battery Connection
			Light Blinks After Capacity	Charging and Current Battery SOC
			Light On After Capacity	Discharging and Remaining SOC
	Communication Connection and Data Transmission		Green Light On	Inverter Communication Module Normal, No Device Connected
			Green light flashing	<b>Green light fast flashing:</b> Communication (When the Bluetooth is connected to the inverter, the indicator light prioritizes indicating "Bluetooth connected: Green light slow flashing") <b>Green light slow flashing:</b> The LED will slow flash after Bluetooth connected



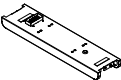
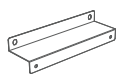

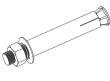

# 4. Structural Installation

## 4.1 Packing List

### Required List

Inverter Packaging Box List					
					
Inverter*1	M 8 *80*2	CT*1	(Right)Trim Panel*1	(Left)Trim Panel*1	COM1*1
					
WiFi*1	L Bracket*2	M5*18 Bracket Screws*2	M5X12 Grounding Screw*2	RJ45 Adapter*1	COM 2*1
					
Backup*1	Grid*1	PV Positive Terminal*N	PV Negative Terminal*N	Quick Installation Manual*1	Certificate of Conformity*1





Base Packaging Box List					
					
Base*1	Floor-Mounted Wall Bracket*1	Leveling Foot*4	Side Mounting Plates*2	Handles*2	Terminal Resistor*1
					
M 8 x80*2	M5x10 Screws*2				

Battery Pack Packaging Box List				
				
Battery Pack*1	M4x12 Screws*4	Trim Panels*1	Trim Panels*1	User Manual*1
				
Certificate of Conformity*1		Fixed Plate*2		

## 4.2 Installation Tools

			
Impact drill( $\phi$ 10mm Drill bit)	Torque wrench	Marker pen	Vacuum cleaner
			
Torque wrench	Torque screwdriver	Tape measure	Spirit level
			
Electric drill(With M6 socket)	Multimeter	Rubber hammer	Wire stripper
			
Wire cutter	Crimping tool (for PV terminals)	Utility knife	RJ45 crimping tool
			
Crimping tool (for AC terminals)	Cable tie	Hot air gun	Heat shrink tubing
			
Dustproof blanket	Photovoltaic plug unlocking tool		

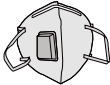
## Personal protective equipment

			
Safety gloves	Safety goggles	Dust mask	Safety shoes

## 4.3 Installation Precautions

- Equipment must be installed strictly according to the installation instructions provided in this manual and local laws and regulations. The warranty service applies only if the equipment is correctly installed and Used properly. If the installation and usage requirements are not followed, the warranty service will not be available.
- The installation location of the equipment should meet local fire protection/environmental protection requirements. The specific installation position should comply with the requirements of the installer/procurement and contract.
- Keep away from areas where children play to avoid accidental contact.
- Install away from walls, pipes, and wiring to avoid drilling through lines and pipes.
- Do not install in direct sunlight.
- Do not install in areas storing highly flammable, explosive, or corrosive materials, or in potentially explosive environments.
- Do not install where cold air blows directly.
- Do not install near television antennas or antenna cables.
- Elevation should not exceed approximately 3000 meters.
- Not in environments with precipitation or humidity (>95%).
- Good ventilation conditions.
- Environmental temperature within the range of -20 °C to +60 °C.
- Wall inclination should be within  $\pm 5^\circ$ .
- The wall on which the equipment is mounted should meet the following conditions:
  - a. The wall surface should be solid and level.
  - b. Solid brick/concrete or equivalent strength installation surface;
  - c. If the wall strength is insufficient, it must be supported or reinforced (e.g., wooden walls, walls covered with thick decorative layers);
- During actual installation, the installation location should comply with local regulations on environmental protection, fire protection, and other related laws. The specific installation location
- Should be determined by the installation engineer, procurement, construction contract, etc.

**Environmental Requirements:**

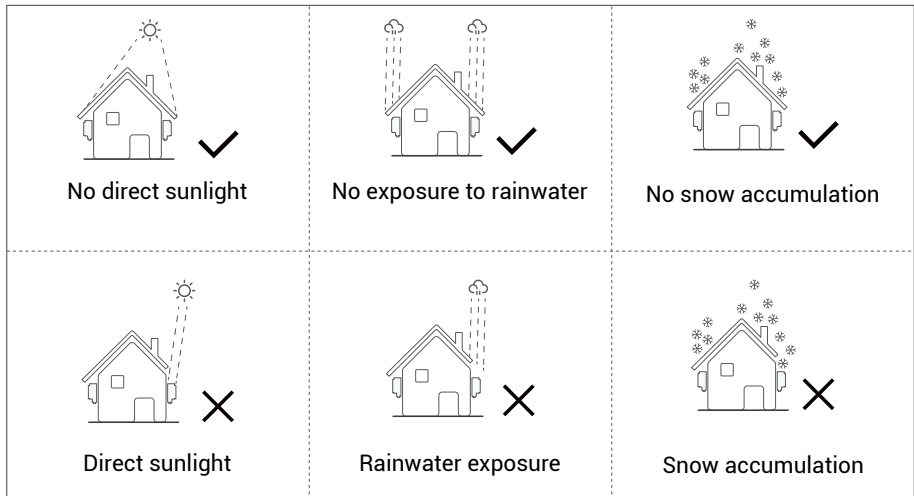

**Installation Location Requirements:**

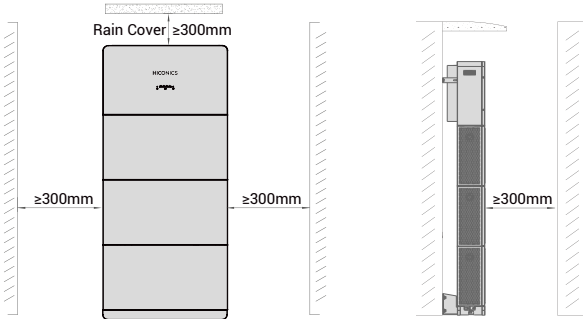

Single Cluster Installation

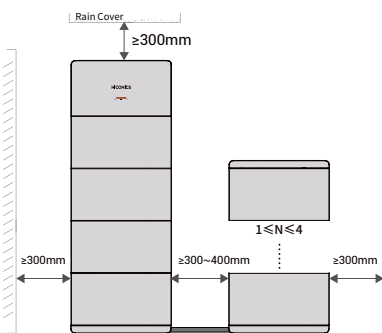

Multi-Cluster Expansion Installation

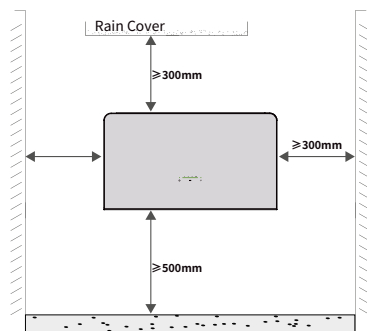

PCS only Wall-Mounted Installation

## 4.4 Inverter Only Wall-Mounted Installation



### Warning

01. When the inverter is not used with the specified battery pack, it must only be wall-mounted, and the corresponding accessory kit must be purchased before installation.
02. Before installing the inverter, ensure that the wall has sufficient load-bearing capacity. The wall load-bearing capacity must be  $\geq 100\text{kg}$ .
03. Before installing the inverter, ensure that the wall is perfectly vertical with no tilt. If the equipment must be installed on a wall or location with a certain angle of inclination, ensure that the angle of inclination  $\theta \leq 15^\circ$ .
04. After completing the installation of the inverter, ensure that the bottom terminals are covered with a cover plate. Failure to do so may result in serious accidents.

01 Mark the holes for fixing the back panel.

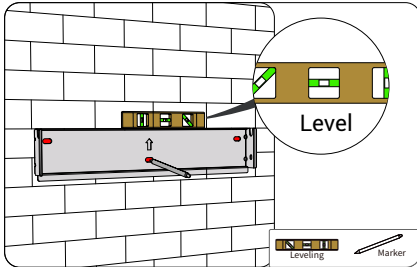

02 Drill holes.

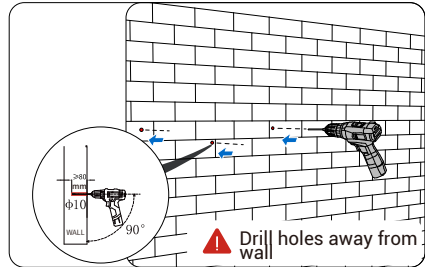

03 Install the expanding screw.

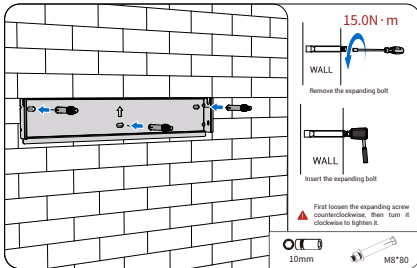

04 Remove the bottom connector screws.

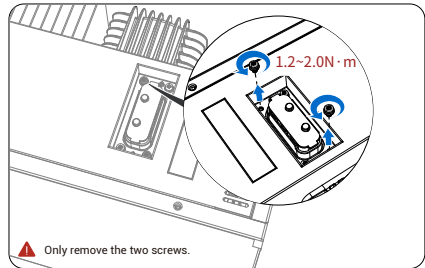

05 Install mounting studs.

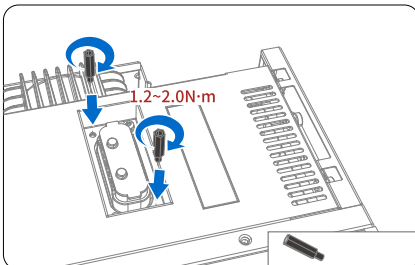

## 06 Install cover plate.

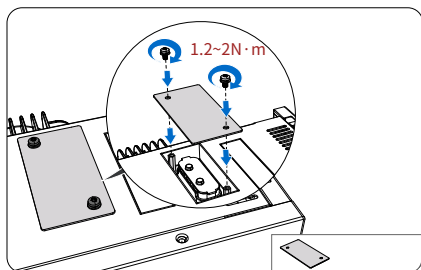
**Danger**

This is very important; you must ensure that the bottom cover plate is installed and securely fastened. Failure to install or secure the cover plate may result in serious accidents.

## 07 Install back panel mounting brackets.

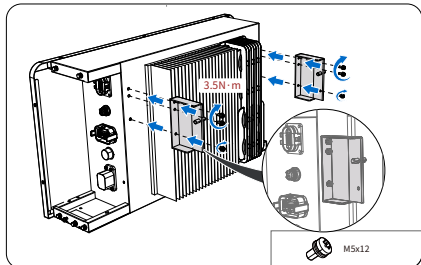

## 08 Install inverter.

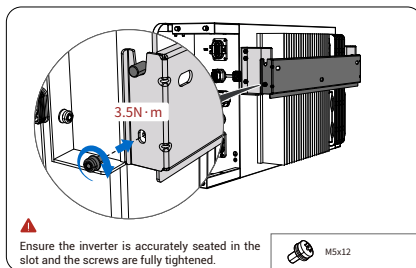

## 09 Install decorative panel.

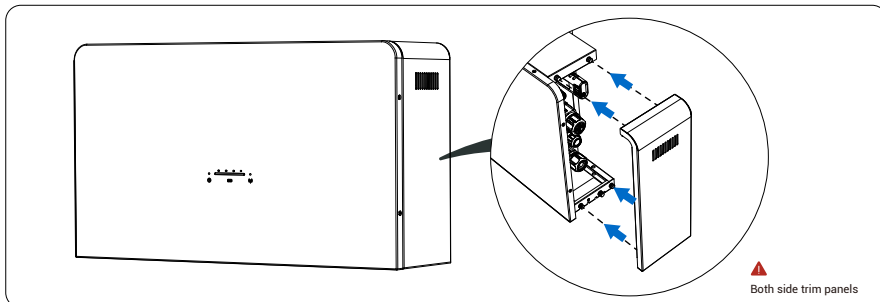

## 4.5 Energy Storage System Installation

The energy storage system includes inverter, battery pack, base, etc. If expansion is required, additional accessory kits must be purchased separately.

### 4.5.1 Base Installation



**Warning**

- 01. Floor-Mounted Installation and Wall-Mounted Installation have different base installation methods. Please install strictly according to the method in this manual.
- 02. If you need to expand multiple clusters, please purchase the corresponding accessory kit.
- 03. When installing on the floor, ensure that the base has been leveled. If on the floor, use foot pads to level the feet.
- 04. When installing on the wall, ensure that the wall has the corresponding load-bearing capacity. Installation is strictly prohibited if the load-bearing capacity is insufficient. The wall load-bearing capacity must exceed Quadruple the total weight.

The total weight is calculated as follows:

$$\text{Base (5kg)} * N1 \text{ (Total base count)} + \text{PCK (50KG)} * N2 \text{ (Total package count)} + \text{PCS (25kg)}$$

#### 01 Base Bracket Installation (Floor-Mounted Installation).

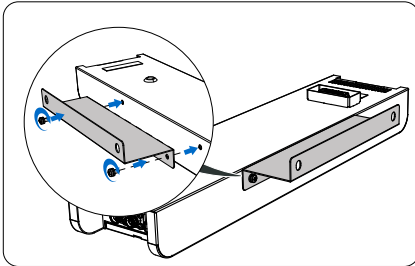

#### 01 Base Bracket Installation (Wall-Mounted Installation).

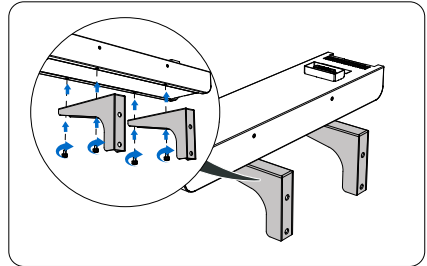

#### 02 Level the Base and Mark Holes (Floor-Mounted Installation).

1. Install leveling feet.

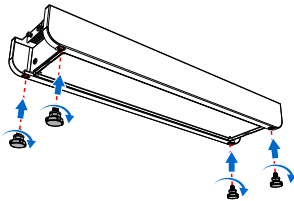

2. Leveling.

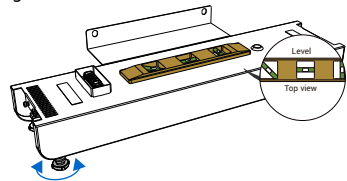

Achieve different height leveling requirements by rotating the leveling feet, and complete leveling once the spirit level indicates it is level.

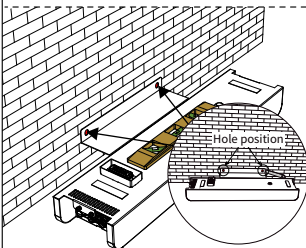

3. Hole position marking.

03 Base bracket drilling.

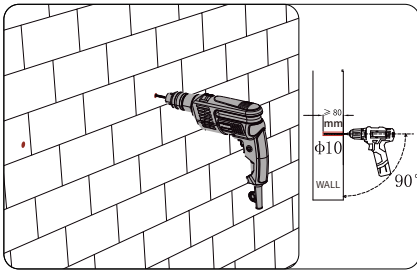

04 Install expansion screws.

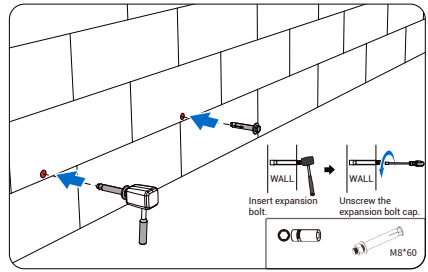

05 Fixing screws, mounting the base (floor mounting).

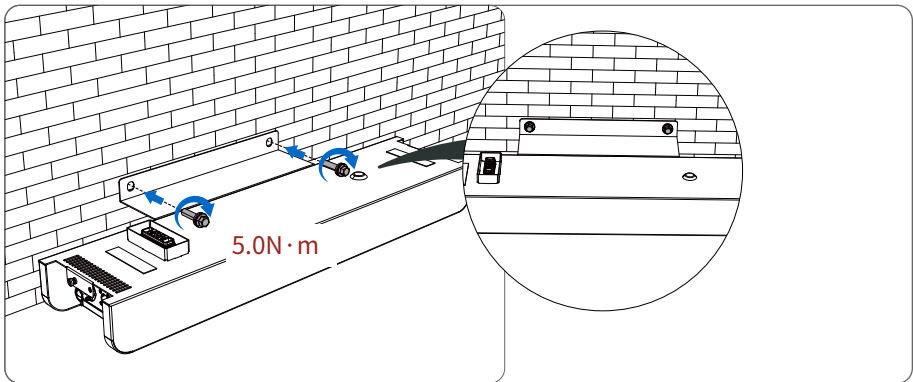

05 Fixing screws, mounting the base (wall mounting).

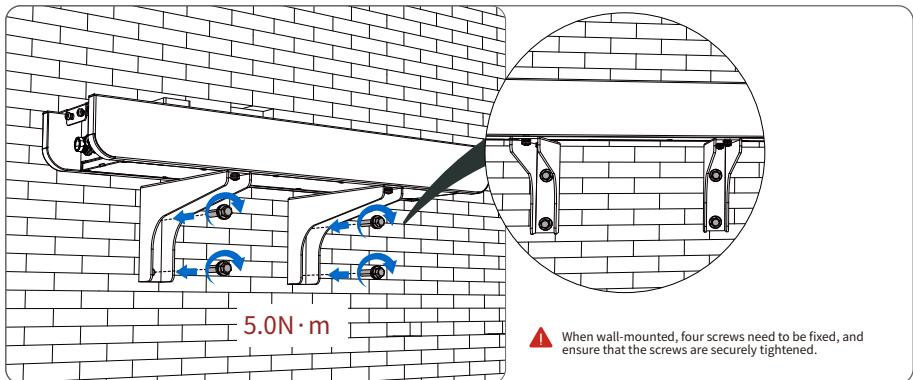

## 4.5.2 Battery Pack Installation



**Warning**

01. Please use the handle provided in the accessories for handling. The handle is located in the high-voltage box packaging box. Ensure the handle is properly engaged before handling.
02. Remove the upper and lower interface protection covers before installing the battery pack.
03. Ensure the previous battery pack is securely fixed before installing the next battery pack.
04. If the battery pack is subjected to impact or falls during handling, it must be inspected and checked by a professional before it can be installed.
05. When the number of battery packs more than 3, the handling process requires the use of the handle and ladder in conjunction.

1. Stacked battery pack

2. Fixed battery pack

3. Install left and right decorative panels

4. Battery pack installation completed.

⚠ The battery pack must be secured (after installing the fixing pieces on both sides) before installing the next battery pack.

## 4.5.3 PCS Installation



**Warning**

01. Two persons are required to move the PCS; one person is strictly prohibited from moving or installing the inverter.
02. When the number of battery packs exceeds three., the moving and installation process must use the handle and ladder together.

01 Mark the holes.

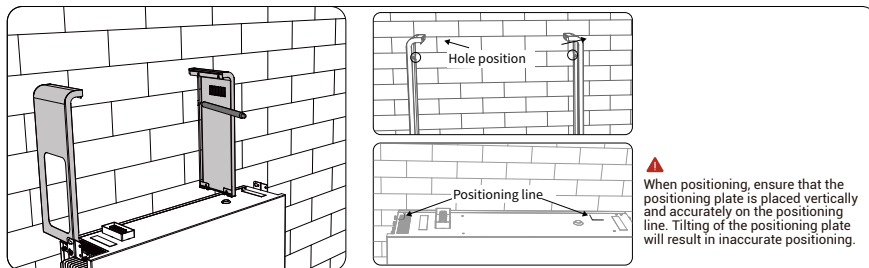

02 Drill the holes



03 Place the inverter.

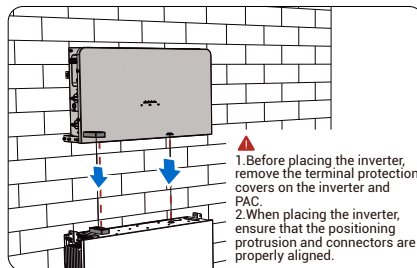

04 Fix the inverter and battery pack.

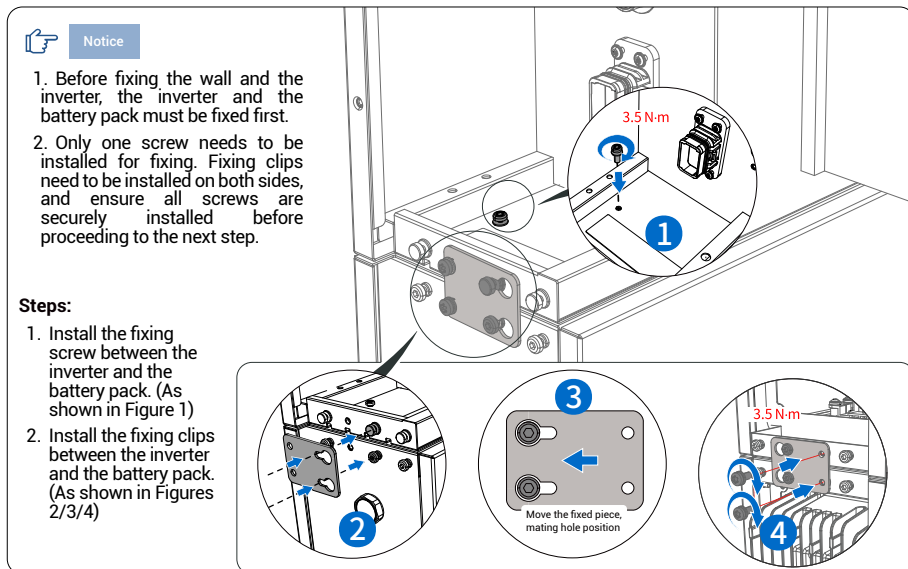

05 Install the wall bracket.

1. Install bracket.

▲ When installing the fixed bracket, the screws do not need to be tightened.

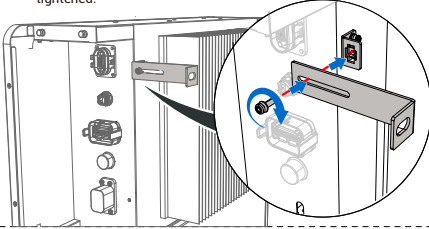

2. Install the expansion bolts to secure the inverter to the wall.

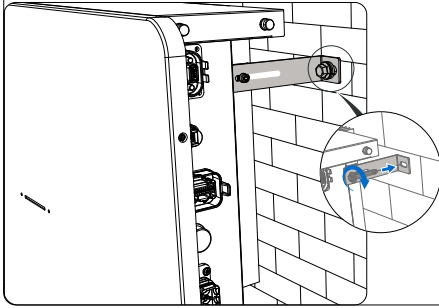

3. Tighten the screws.

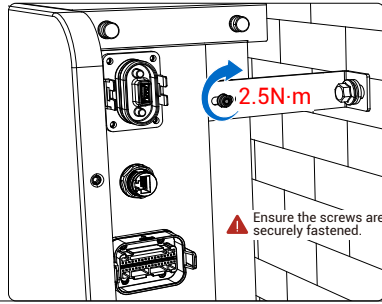

06 Install decorative panel.

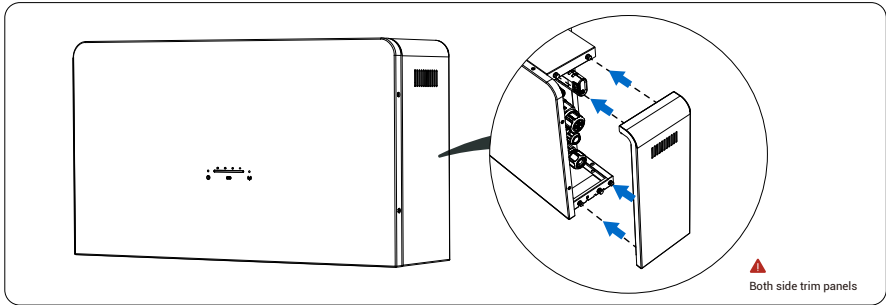

## 4.6 System Removal



**Danger**

Before disassembly, ensure that all switches have been turned off (the shutdown sequence can be found in the Power On/Off section), and all wiring has been removed (the port removal method can be found in the corresponding Port Connection section).

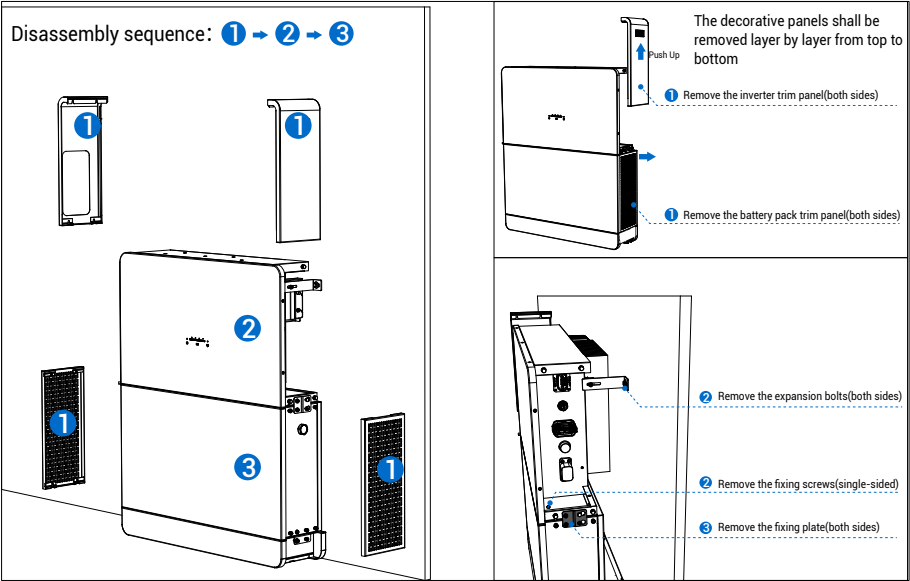

# 5. Electrical Installation

## 5.1 Wiring Requirements

Version E is applicable for areas where N and PE are separated within the distribution box, such as China, Germany, Italy, and most other countries.

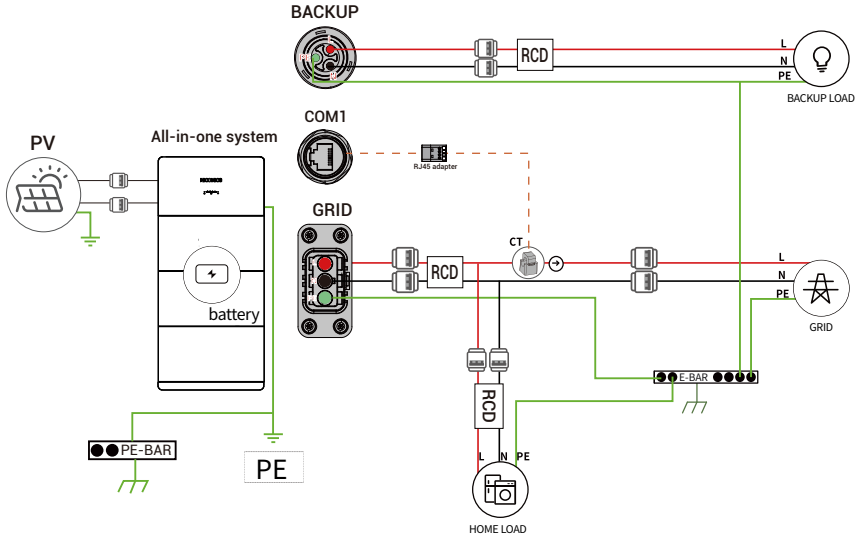

Version I is applicable for areas where N and PE are connected within the distribution box, such as Australia, New Zealand, South Africa, and other

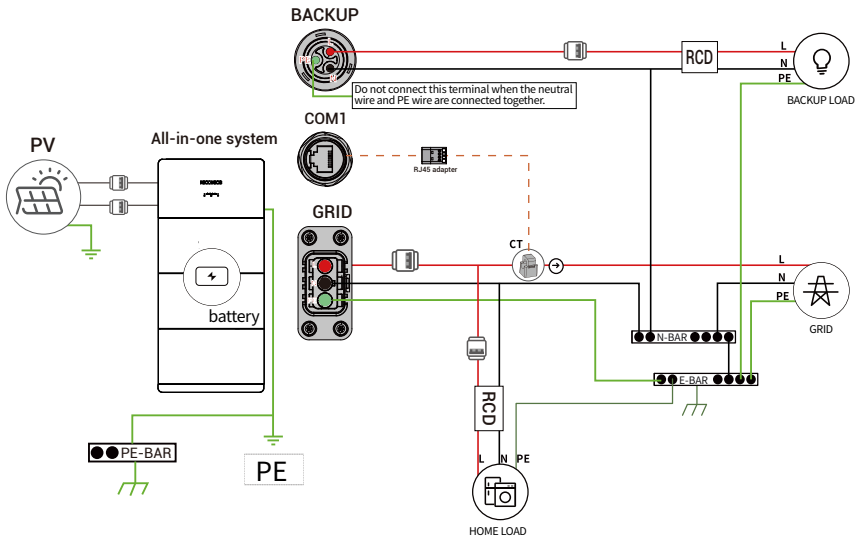

To avoid unnecessary hazards and personal injury during installation, the wire harness must be connected strictly in the following sequence. Installation sequence:

### Installation order:

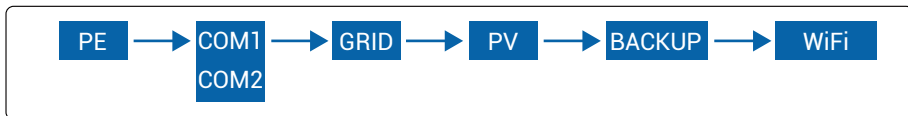

	Wire Size	Cable Size
PV	6mm <sup>2</sup>	
PE	10mm <sup>2</sup>	Standard grounding wire
COM1	10mm <sup>2</sup>	Standard network cable
COM2	1.5mm <sup>2</sup> max	4.5mm≤OD≤6.5mm
GRID	10mm <sup>2</sup>	≤24mm
BACKUP	4~6mm <sup>2</sup>	≤15.5mm

## 5.2 Grounding Wire Installation

### Precautions for Installing Grounding Wire:



#### Warning

01. Ensure the ground wire diameter meets the system requirements.
02. The grounding wire harness must be installed before installing other wire harnesses.
03. When disassembling the equipment, the grounding wire harness must be the last to be removed.
04. The ground wire harness must be securely installed; poor contact may pose an electric shock risk.

### 01 Crimp the ground wire harness.

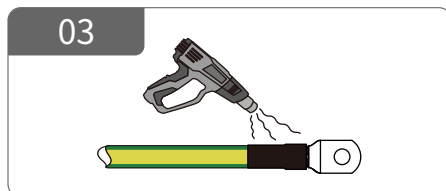
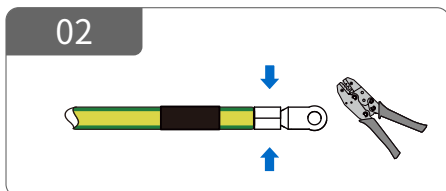
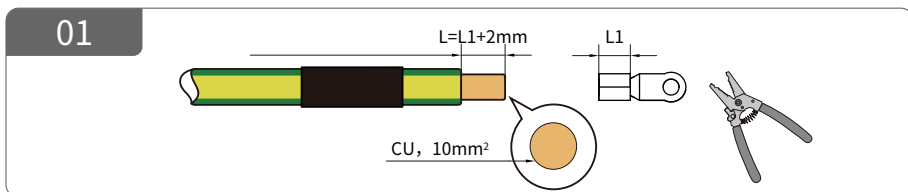

02 Install the ground wire.

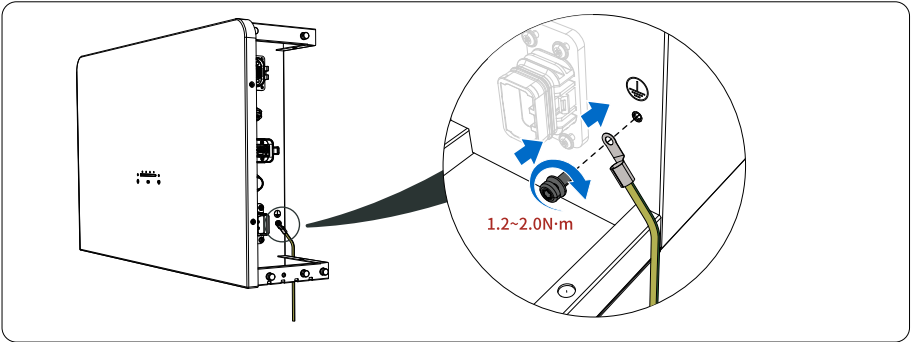

5.3 CT/METER communication interface connection

Pin definition

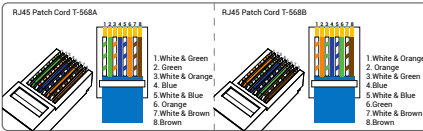

PIN	Description	PIN	Description
1	RS485A Meter	5	CT3+
2	RS485B Meter	6	CT2-
3	CT2+	7	CT1+
4	CT3-	8	CT1-

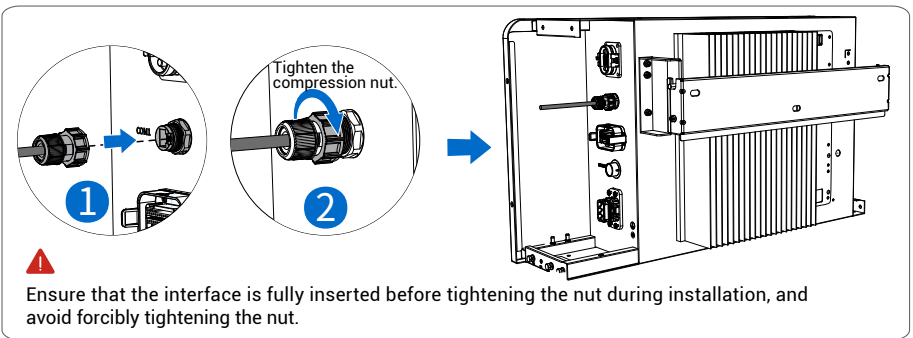
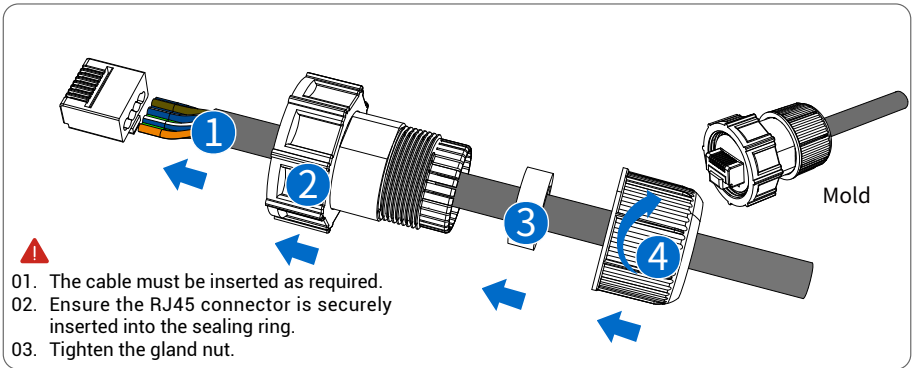

Connect the RJ45 adapter:

If COM1 needs to connect to a meter or CT, an RJ45 adapter must be used for conversion. The conversion method for the RJ45 adapter is as follows:

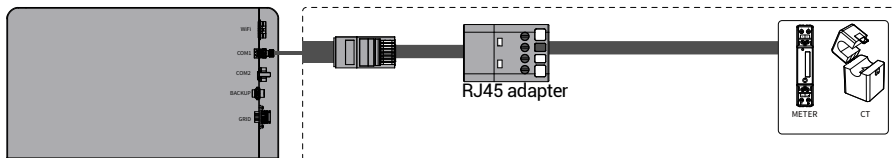

RJ45 adapter PIN definition:

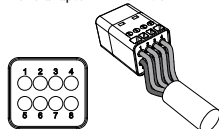

PIN	Description	PIN	Description
1	RS485A Meter	5	CT3+
2	RS485B Meter	6	CT2-
3	CT2+	7	CT1+
4	CT3-	8	CT1-

- This example uses a single-phase electric meter. For three-phase, the corresponding three-phase electric meter should be connected.
- CT is a standard accessory of the product. If an electric meter needs to be installed, the user must purchase it separately.
- The CT is subject to the actual product, and when connecting the CT, the arrow should point towards the grid side.
- There are multiple ways to connect the electric meter and CT. Users can connect them according to their actual situation. For specific connection methods, refer to the product user manual.

## 5.4 COM Communication Interface Connection

### Pin definition

PIN	Definition	PIN	Definition
1	DRM1/5	2	DRM2/6
3	DRM3/7	4	DRM4/8
5	REF	6	COM/DRM0
7	5V COM	8	GND
9	DI3	10	DI4
11	485A	12	485B
13	D03A	14	D03B
15	D04A	16	D04B
17	D05A	18	D05B

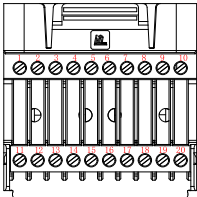

PIN (Interface 1)	Definition	PIN (Interface 2)	Definition
1	DSP CANL	1	DSP CANL
2	DSP CANH	2	DSP CANH
3	ARM CANH	3	ARM CANH
4	ARM CANL	4	ARM CANL
5	Lf Sync	5	Lf Sync
6	GND_Sync	6	GND_Sync
7	485 2A	7	485 2A
8	485 2B	8	485 2B

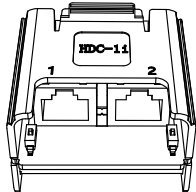

# Installation tools



Open-end wrench



Wire stripper



Hexagonal rivet pliers

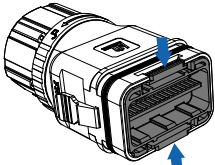

When removing the terminal body, simply pinch it as shown in the diagram and pull it out.

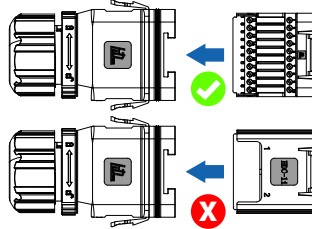

**Warning**

When inserting the terminal body, ensure the direction is correct and do not insert it in reverse.

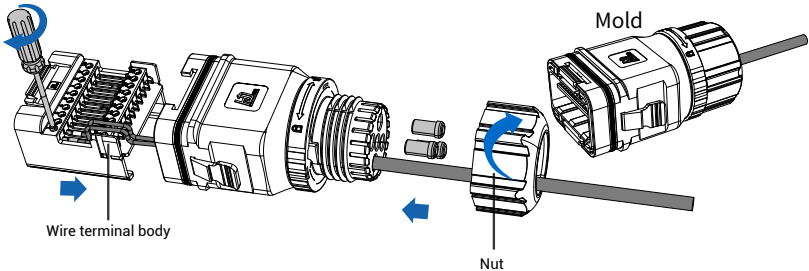

01. Remove the plug insert and, according to the diagram sequence, thread the wire and connect the terminals.
  02. Insert the wire into the corresponding terminal.
- Note:** The terminals must be inserted accurately according to the definition.
03. Use a flathead screwdriver to crimp the wire, and tighten the screw to a torque of 1.2+/-0.1N·m
  04. Arrange the core wires so that there is no overlapping over the insulator core area, then insert the insulator core into the body, which should produce a 'click' sound.
  05. Insert the plug into the body and block any unused holes with a stopper.
  06. Screw the conduit nut onto the body to a torque of 2.5+/-0.1N·m, completing the installation.

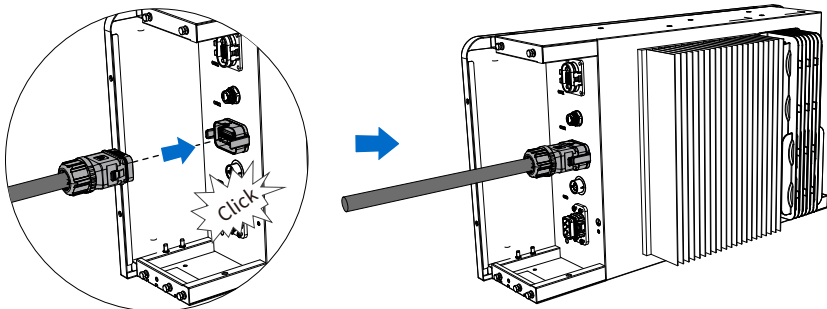



**Warning**

This interface is only used for parallel operation, and the connection method is shown in the figure.

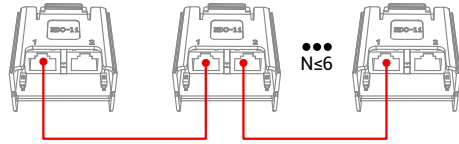

**DRM Interface (Optional)**

This interface is a dry contact (only for Australia)

DRM means demand response enable device. The AS/NZS 4777.2:2020 required inverter need to support demand response mode (DRM). This function is for inverter that comply with AS/NZS 4777.2:2020 standard. Inverter is fully comply with all DRM.



**Notice**

Strictly connect according to the PIN definition.

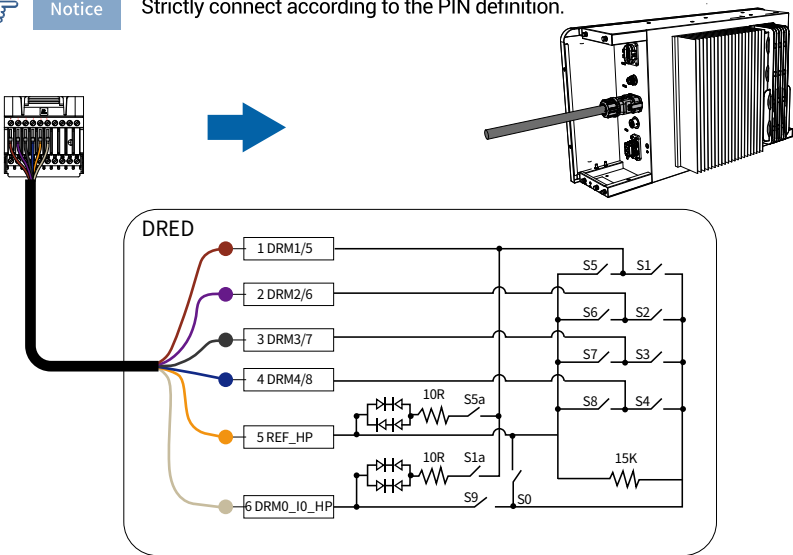

DRM0	DRM1	DRM2
DRM3	DRM4	DRM5
DRM6	DRM7	DRM8

DRM label

PIN	Definition	PIN	Definition
1	DRM1/5	2	DRM2/6
3	DRM3/7	4	DRM4/8
5	REF	6	COM/DRM0

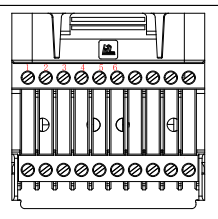

## 5.5 GRID Connection

Before connecting to the grid, install an independent AC circuit breaker between the inverter and the AC input power. This will ensure that the inverter can be safely disconnected during maintenance, and provide complete protection against overcurrent in the AC input. It is recommended to use a wire size of 10mm<sup>2</sup>, with a circuit breaker rated at 63A.



**Warning**

The connector is labeled with "L", "N", and "PE" symbols; the live wire must be connected to the "L" terminal; the neutral wire must be connected to the "N" terminal; the ground wire must be connected to the "PE". Failure to comply with local standards, regulations, or the company's recommended values

Using an oversized AC switch may prevent timely and safe disconnection in the event of a fault, leading to serious failures.

### Installation tools



Open-end wrench



Wire stripper



Hexagonal rivet pliers

Use professional tools to strip the cable insulation according to the requirements in the table below.

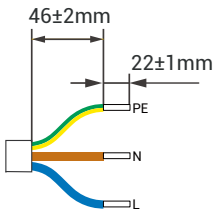

**!** Crimp the terminal using a crimping tool. It is recommended to use a quadrilateral crimping plier.

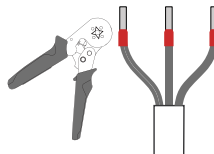

#### Terminal selection

Model	Insulated cord end Terminal	Wire Size	Recommended model
3-8kW		10mm <sup>2</sup>	ENY10-18

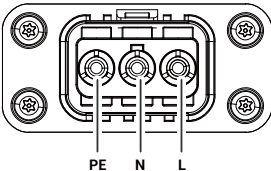

**1**

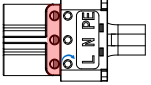

Observe through the visual hole to ensure the terminal is properly inserted.

**2**

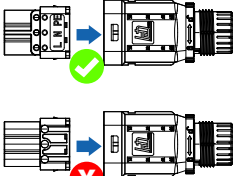

**Warning**

When inserting the terminal body, ensure the direction is correct and do not insert it in reverse.

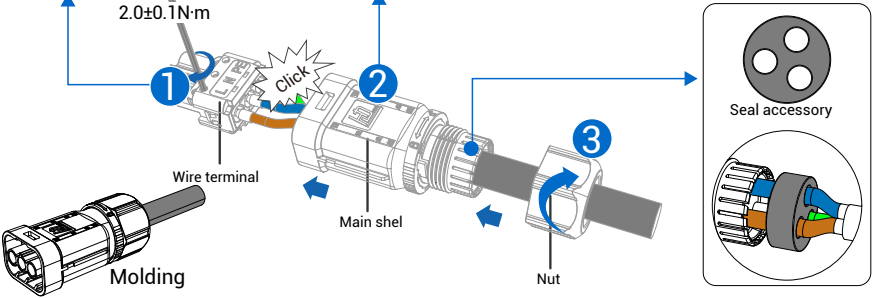

2.0±0.1N·m

1 Wire terminal

Click

2 Main shell

3 Nut

Molding

Seal accessory

1. After crimping the stripped wire with the insulated terminal, sequentially thread the locking nut, insert the main cable into the rubber core according to the wire sequence, ensuring the insulated terminal is flush with the surface of the rubber core, and tighten the screw with a torque of 2.0±0.1N·m.
- Note: Wiring must strictly follow the L, N, and PE labels on the plug.
2. Insert the rubber core into the main body until you hear a "click" sound.
3. Use an open-end wrench to tighten the nut, accompanied by "click, click" sounds.

**▲** 1. Ensure that the plug is securely inserted and cannot be pulled out when pulled back.  
 2. Ensure sufficient turning radius during installation to reduce wiring harness stress.

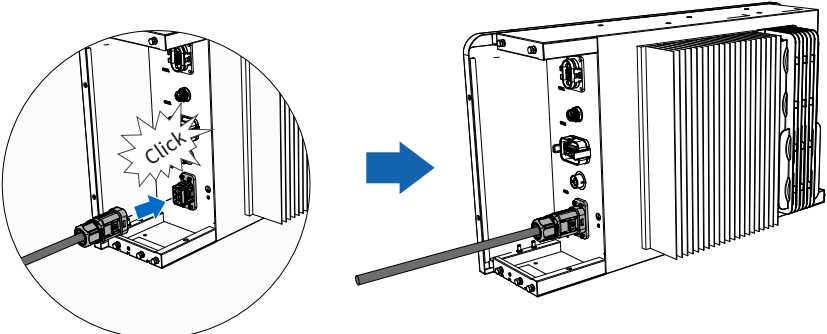

## Unlock terminal

If you need to remove the terminal, please follow the steps below.

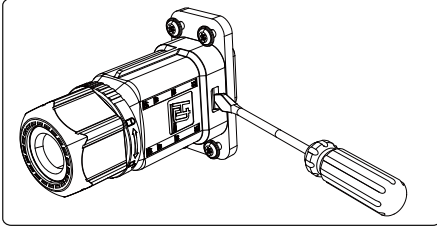

Use a screwdriver to align with the unlocking position, press down, and hold the female connector while pulling it backward to complete the separation of the male and female connectors.

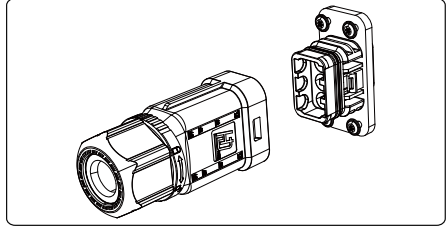

Separation of the female connector and the board-end connector.

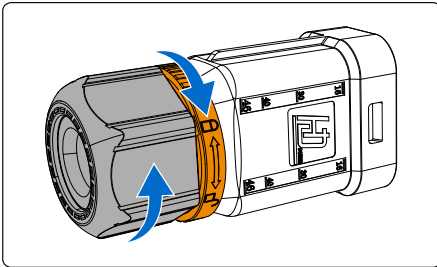

Hold the unlocking buckle with one hand and rotate it in the direction indicated, while rotating the nut in the opposite direction with the other hand.

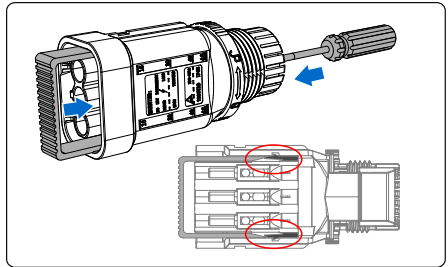

Use a screwdriver to pry open the red circle positions on both sides to complete the disassembly.

## 5.6 PV Installation

### 5.6.1 Precautions



#### Warning

- Before connecting the photovoltaic module, install a separate DC circuit breaker between the inverter and the photovoltaic module.
- Before connecting the photovoltaic module, ensure that all 'DC SWITCH' on the inverter are set to the 'OFF' position. Otherwise, the high voltage of the inverter may cause an electric shock hazard.
- Equipment damage caused by incorrect wiring is not covered under the equipment warranty.
- Only qualified electrical technicians should perform electrical connection operations.
- When performing electrical connections, operators must be equipped with personal protective equipment.
- To prevent poor cable connections due to excessive pulling force, it is recommended to reserve some slack in the cable before connecting to the corresponding terminal.
- To ensure the safe and efficient operation of the system, it is important to use appropriate cables for connecting PV array. To reduce the risk of injury, please use the following recommended cable sizes.

Wire size	Wire diameter (mm <sup>2</sup> )
12AWG	4

- To avoid equipment damage, do not connect PV array that may have leakage risks to the inverter. For example: grounded PV array.
- When selecting suitable PV array, please ensure to consider the following parameters:
  01. The open-circuit voltage (V) of the PV array does not exceed the maximum open-circuit voltage of the inverter's PV array.
  02. The open-circuit voltage (V) of the PV array should be higher than the minimum.
- PV array frame can be grounded, however, the PV array conductors (positive and negative) shall be ungrounded or float.

#### Maximum DC voltage limit

Model	MEI2-HS3H-AIO	MEI2-HS3.68H-AIO	MEI2-HS3.8H-AIO	MEI2-HS4H-AIO
Maximum DC Voltage (V)	550Vd.c.	550Vd.c.	550Vd.c.	550Vd.c.
MPPT Voltage Range (V)	80-500Vd.c.	80-500Vd.c.	80-500Vd.c.	80-500Vd.c.
Model	MEI2-HS4.6H-AIO	MEI2-HS5H-AIO	MEI2-HS5H-AIO2	MEI2-HS6H-AIO
Maximum DC Voltage (V)	550Vd.c.	550Vd.c.	550Vd.c.	550Vd.c.
MPPT Voltage Range (V)	80-500Vd.c.	80-500Vd.c.	80-500Vd.c.	80-500Vd.c.
Model	MEI2-HS8H-AIO			
Maximum DC Voltage (V)	550Vd.c.			
MPPT Voltage Range (V)	80-500Vd.c.			

### 5.6.2 Installation Steps

Step 1: Inspect the photovoltaic module.

- 01. Use a voltmeter to measure the module array voltage.
- 02. Please correctly check the PV+ and PV- from the photovoltaic string combiner box.
- 03. Ensure that the impedance between the positive and negative terminals is at the MΩ level, and the impedance between the photovoltaic positive terminal and ground should also be at the MΩ level.

Step 2: Disconnect the DC connectors.

Step 3: Wiring

- 01. Select 4 ~6mm<sup>2</sup> wire to connect with the cold crimp terminals.
- 02. Strip 7-8mm of insulation from the end of the wire.
- 03. Insert the insulation layer into the pin contact point and secure it with a crimping tool.

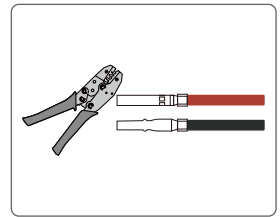
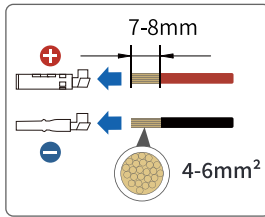
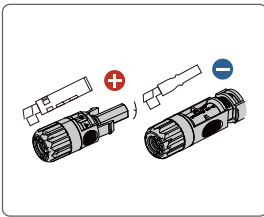

Step 4: Install the pin contact through the cable terminal assembly to the back of the male or female connector. When you feel or hear a 'click,' the pin contact is properly installed.

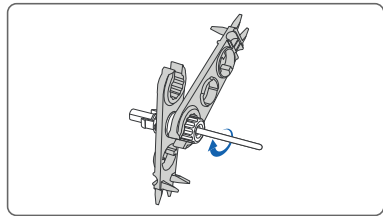
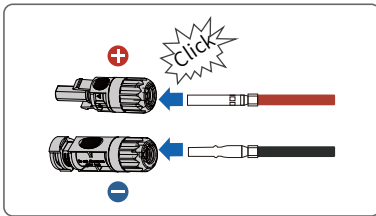

Step 5: Insert the photovoltaic connector into the corresponding photovoltaic connector on the inverter.

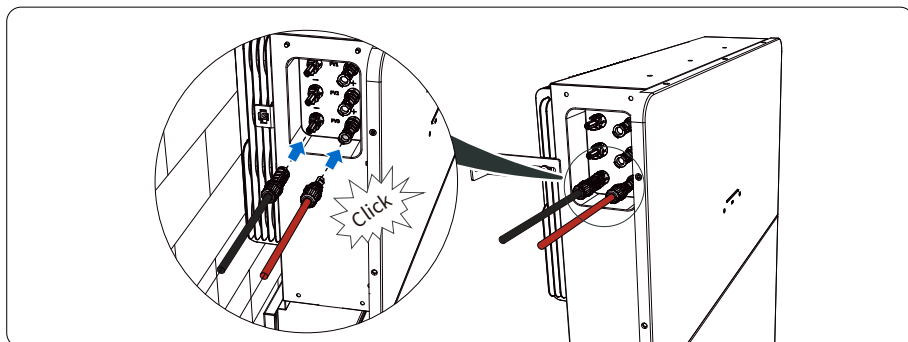

## PV module removal

Insert the removal tool into the corresponding hole, press firmly, and pull the terminal out when you hear a "click."

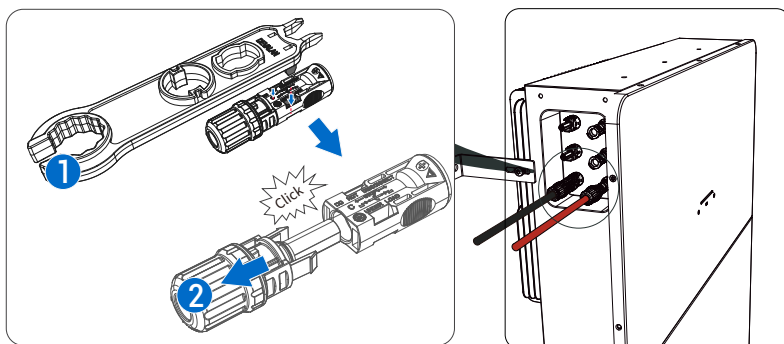

## 5.7 BACKUP Connection

Before connecting the load, install an independent AC circuit breaker between the inverter and the load. This will ensure that the inverter can be safely disconnected, and full protection against overcurrent. It is recommended that the cable size be 6mm<sup>2</sup>, and the rated capacity of the circuit breaker be 32A.



### Warning

The connector is internally marked with the symbol "L", "N", and "PE"; the live wire must be connected to the "L" terminal; the neutral wire must be connected to the "N" terminal; the ground wire must be connected to the "PE".

Using an oversized AC switch that does not meet local standards, regulations, or the company's recommended values may result in the inability to disconnect safely and promptly during abnormal conditions, leading to severe faults.

## Installation tools



Open-end wrench



Wire stripper



Hexagonal rivet pliers



Use specialized tools to strip the cable insulation according to the requirements in the table below.

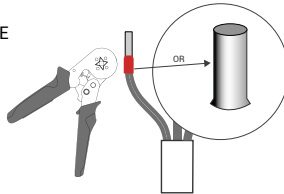
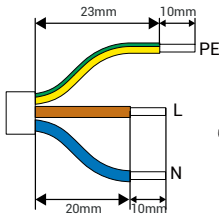

Terminal selection

Insulated cord end Terminal	4mm <sup>2</sup>	Recommended model E4012
Non-insulated cord end Terminal	6mm <sup>2</sup>	Recommended model EN6012

⚠ It is recommended to use a quadrilateral crimping plier.

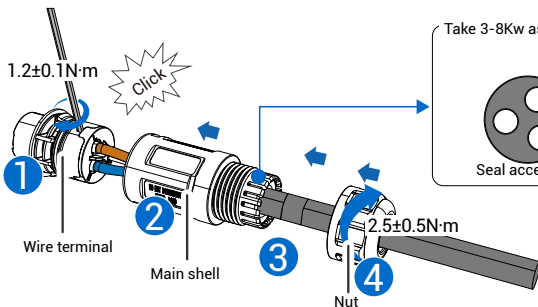

Take 3-8Kw as an example

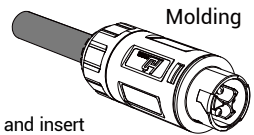
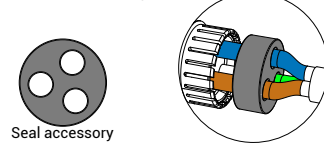

1. Use a crimping tool to crimp the terminal, attach the parts to the cable, and insert them into the terminal holes according to the wire sequence. Use an inner hex screwdriver to crimp the wires, tightening the screws with a torque of  $1.2 \pm 0.1 \text{ N}\cdot\text{m}$ .

Note: Wiring must be done according to the L, N, and PE labels on the plug.

2. Insert the rubber core into the main body until you hear a "click" sound.

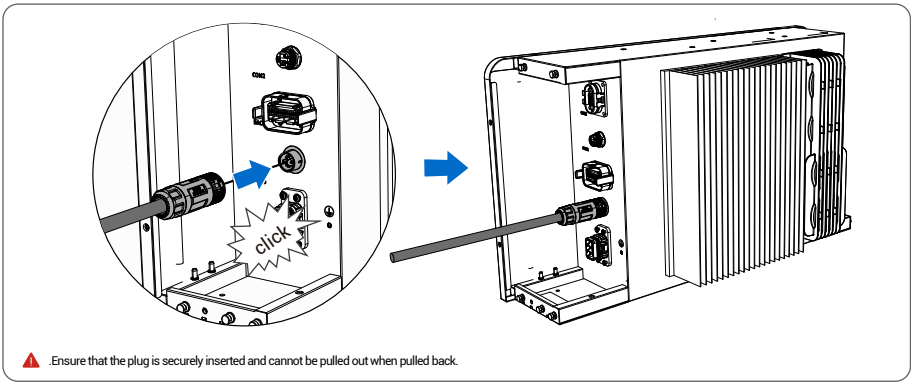

## Unlock terminal

If you need to remove the terminal, please follow the steps below.

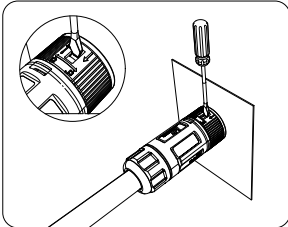

Use the flat-head screwdriver installation icon to flip the unlock lock (skip this step if you use a tool to unlock the lock)

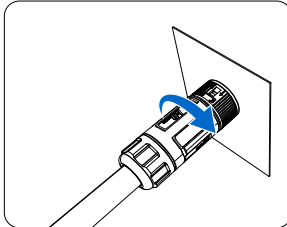

Rotate the latch as shown

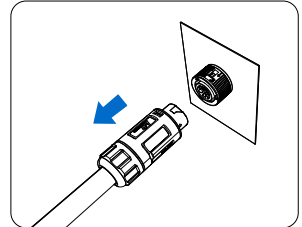

Remove the female end of the cable to unlock the account

## Dust Cover

▲ When the BACKUP port is idle, The dust cover needs to be inserted to protect the interface and avoid accidental touches.

The steps for plug installation and removal are as follows.

Installation Procedure

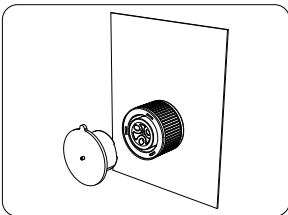

Insert the dust cover as indicated by the safety arrow

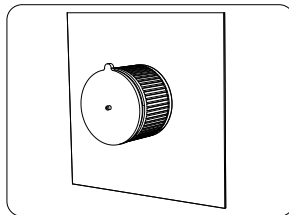

complete the installation

Unlock instructions

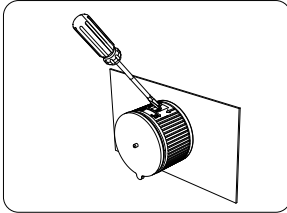

Use the flat-head screwdriver installation icon to flip the unlock lock (skip this step if you use a tool to unlock the lock)

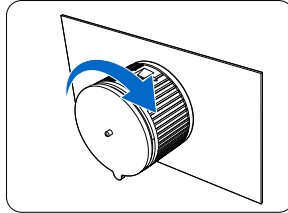

Rotate the latch as shown

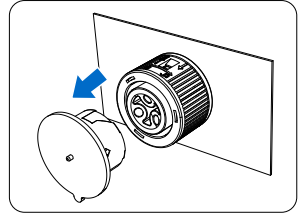

Remove the dust cover, Complete-disassembly

## 5.8 WiFi Module Installation

### 5.8.1 Install the WiFi Module

The WiFi port is a port for operating and monitoring the PCS or system via the internet. The Wi-Fi port supports inserting a USB portable storage device for local upgrades.

Basic Parameters of the WiFi module:

Category	Parameter	Value	
Wireless Parameters	2.4G Wi-Fi Frequency Band	2412MHz~2472MHz, Maximum Transmission Power: 17.99dBm	
Bluetooth	Bluetooth version	BLE5.1	
	BLE frequency range	2402MHz~2480MHz, maximum transmission power: 9.28dBm	
Hardware parameters	Operating voltage	DC5V~DC12V	
	Operating power	1.5W	
	Indicator lights		One set of device connection communication indicator lights
			One set of network connection indicator lights
			One set of operating status indicator lights
	Operating temperature	-30°C~+70°C	
	Operating humidity	10%-90% relative humidity, no condensation	
Protection Rating	IP66		
External Interface	USB Port		

### WiFi Dongle Interface Definition:

Pin	Description	Pin	Description	Pin	Description	Pin	Description	Pin	Description
1	VBUS	2	D-	3	D+	4	GND	5	SSTX-
6	SSTX+	7	RESET	8	RS485-B	9	RS485-A		

## Installing the WiFi Module:

01. The WiFi dongle is an external plug-in.
02. Remove the port protective cover when installing the WiFi antenna.
03. Ensure the WiFi antenna is fully aligned with the device's card slot and securely inserted (you should hear a 'click'), otherwise the WiFi antenna will not function properly.
04. This section only demonstrates the installation of the WiFi antenna. The debugging and activation of the WiFi antenna please refer to the Quick Installation Guide for the WiFi module. To obtain the Quick Installation Guide, scan the QR code below:

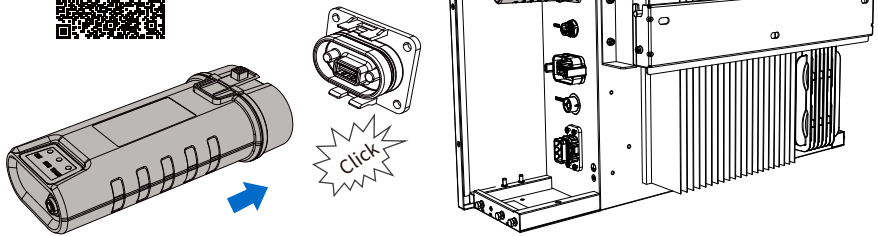

**Warning**

Do not remove the SETTING soft rubber button on the data acquisition antenna body.

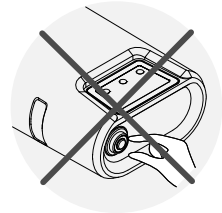

## 5.8.2 Device Upgrade

The USB port can be used to insert other storage devices (such as a USB drive) for device upgrades. Download the latest software from the official website. After inserting the USB drive, the program will upgrade automatically, and you will hear a beep indicating that the OTA upgrade is complete.

This function is applicable to after-sales repair personnel.

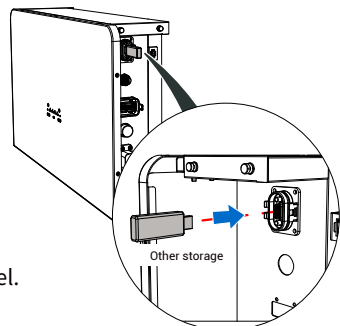

## 5.9 Battery System Expansion

If it is necessary to increase the battery capacity by adding battery modules, the following operations can be performed whether it is an initial installation or after the equipment installation is completed.



**Danger**

01. It is strictly prohibited to use battery packs of different types or brands together, as mixing battery packs may cause serious property damage or personal injury.
02. When expanding the battery system, a separate expansion accessory kit must be purchased.
03. The structural installation during expansion is the same as for a single cluster, refer to the 'Energy Storage System Installation' section of this manual for installation procedures.
04. Ensure the distance between clusters is  $\geq 600\text{mm}$  during expansion installation.
05. When expanding a single PCS, the number of PACKs  $\leq 12$ .

### 5.9.1 Single Unit Expansion Method

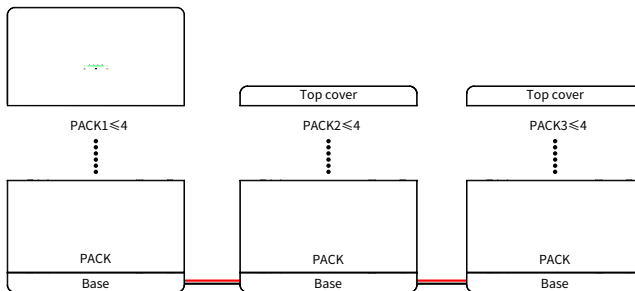

- Capacity 5.1 kWh: 1× Battery Module + 1× PCS + 1× Base
- Capacity 10.2 kWh: 2× Battery Modules + 1× PCS + 1× Base
- Capacity 15.3 kWh: 3× Battery Modules + 1× PCS + 1× Base
- Capacity 20.4 kWh: 4× Battery Modules + 1× PCS + 1× Base
- Capacity 25.5 kWh: 5× Battery Modules + 1× PCS + 2× Bases + 1× Top Cover
- Capacity 30.6 kWh: 6× Battery Modules + 1× PCS + 2× Bases + 1× Top Cover
- Capacity 35.7 kWh: 7× Battery Module + 1× PCS + 2× Base + 1× Top Cover
- Capacity 40.8 kWh: 8× Battery Module + 1× PCS + 2× Base + 1× Top Cover
- Capacity 45.9 kWh: 9× Battery Module + 1× PCS + 3× Base + 2× Top Cover
- Capacity 51.0 kWh: 10× Battery Module + 1× PCS + 3× Base + 2× Top Cover
- Capacity 56.1 kWh: 11× Battery Module + 1× PCS + 3× Base + 2× Top Cover
- Capacity 61.2 kWh: 12× Battery Module + 1× PCS + 3× Base + 2× Top Cover

Expansion Harness:

DC Power Harness (-)	DC Power Harness (+)	Communication Harness

The length of all the above harnesses is: 1000mm

### 5.9.1 Base Harness Connection

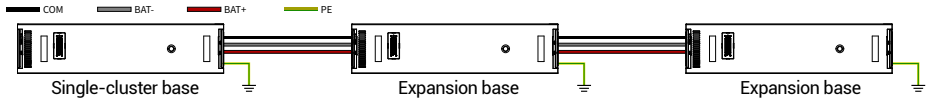

01 Remove the protective side panel.

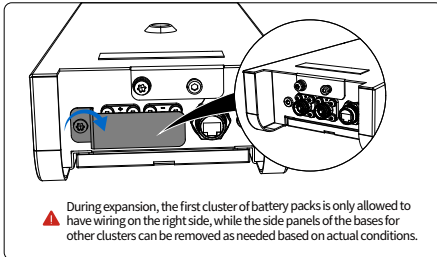

02 Remove the terminal resistor.

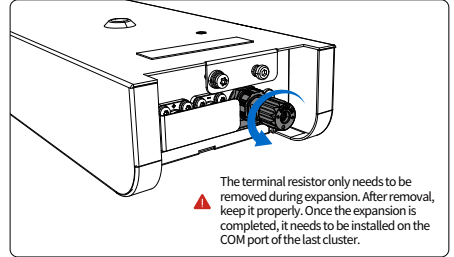

03 Connect the communication wiring harness.

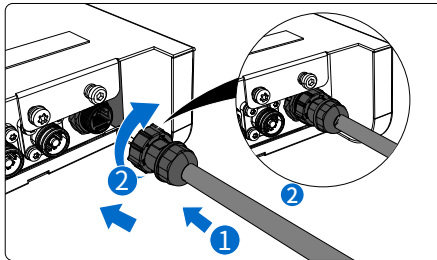

04 Connect the protective ground wire.

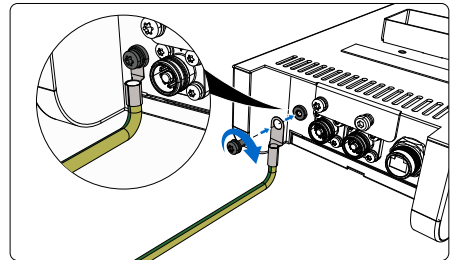

05 Connect the DC power supply harness (+).

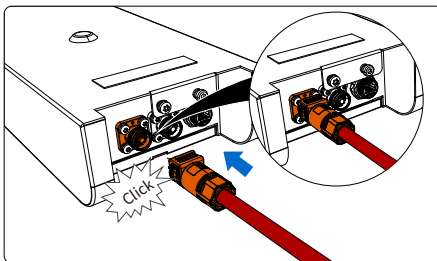

06 Connect the DC power supply harness (-).

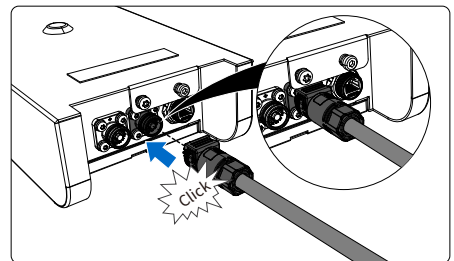

### 07 Install terminal resistor.

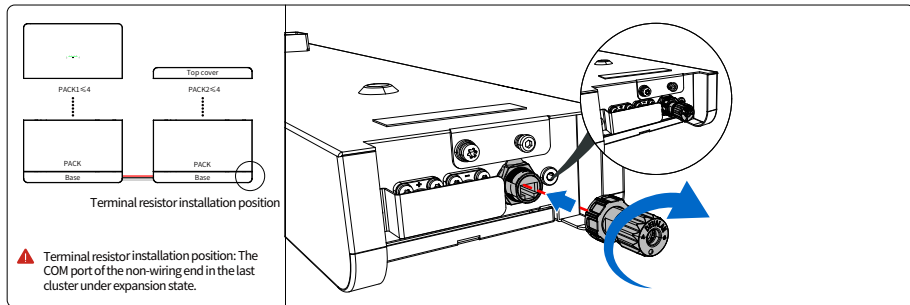

## 5.9.2 Install the top cover

### 01 Position the expansion bolt.

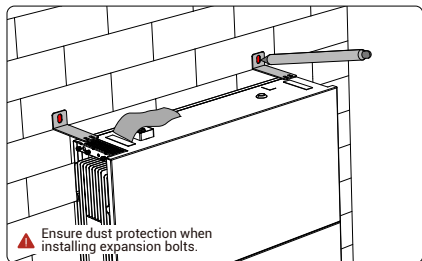

### 02 Install the expansion bolt.

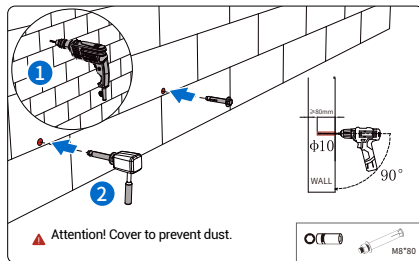

### 03 Fixed Wall Mounting Bracket.

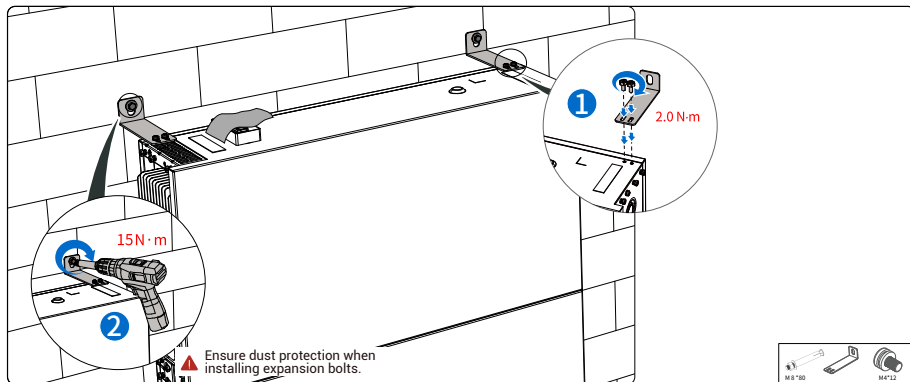

### 04 Side Mounting Bracket Installation.

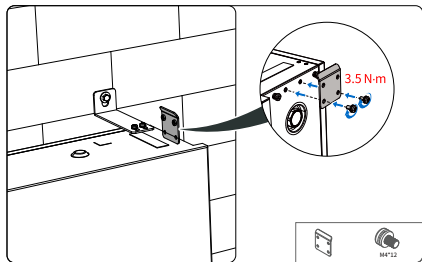

06 Installation of the Top Cover.

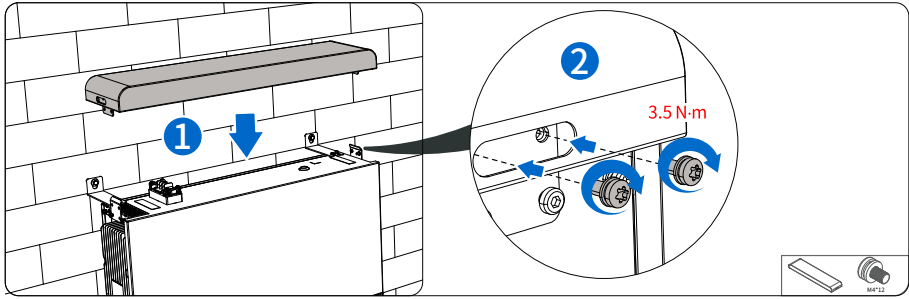

### 5.9.3 Parallel connection of multiple units

**Note:** The number of devices cannot exceed 6 when operating in parallel.

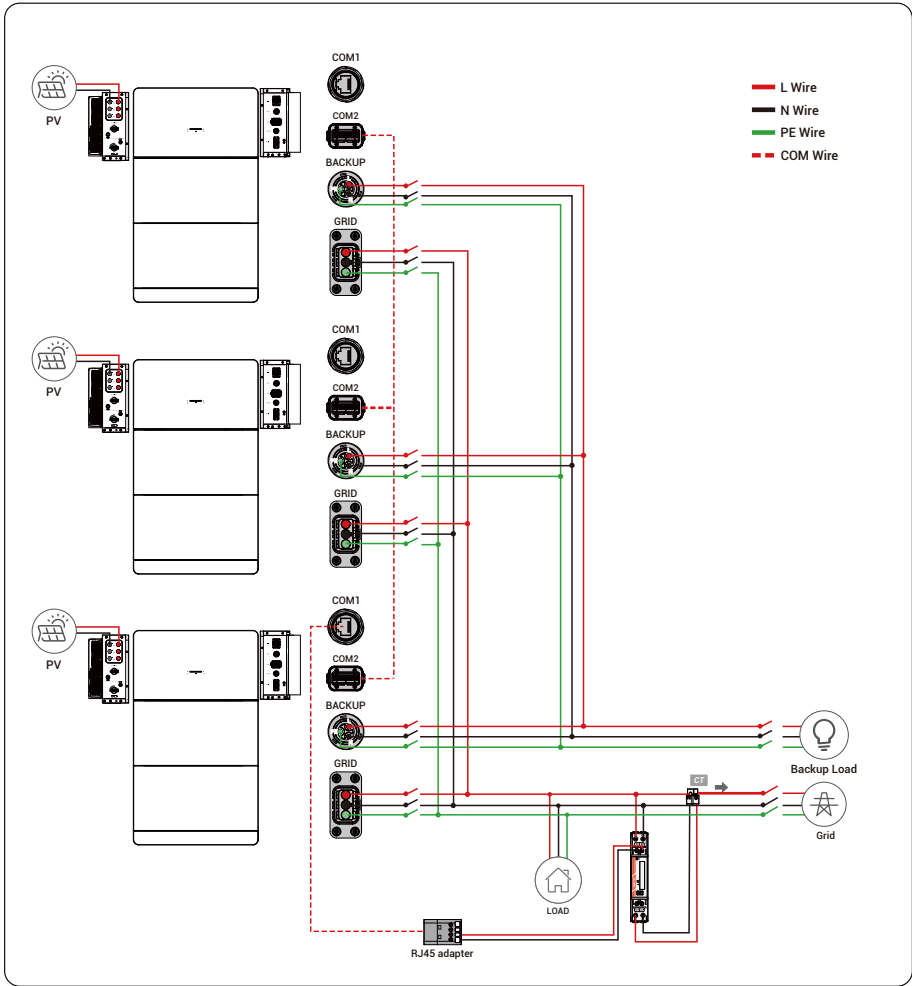

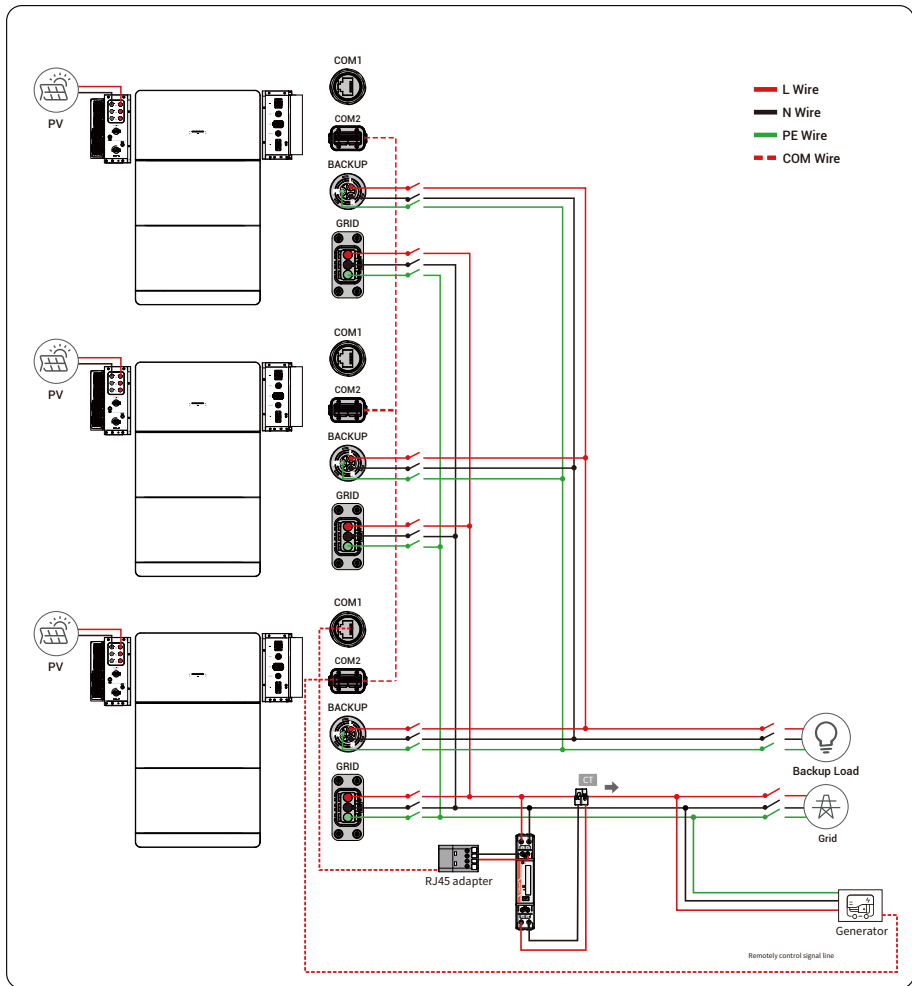

### 5.10 Electric Meter and CT Connection Methods

The inverter should be used in conjunction with an electric meter (optional) or a current transformer (referred to as CT) to monitor household electricity usage. The electric meter or CT can transmit relevant power data to the inverter or cloud platform, making it convenient for users to read at anytime.



**Attention**

Ensure that the main power supply of the grid and the PV switch and battery switch are disconnected during installation. The CT or electric meter must be connected to the inverter; otherwise, the inverter will issue an alarm; The electric meter (optional) must use the company-specified model, otherwise it will not be compatible with the inverter;



**Attention**

The CT should be placed near the grid. If the current meter test passes but the inverter still fails to achieve output power (power is uncontrollable or always outputs 0 power), please check the installation position of the CT.

#### Installation Steps:

Step 1: The installer will prepare network cables, the length of which must be determined based on the site environment.

Step 2: Prepare communication lines, power cables, and tools for connecting the electric meter.

Step 3: Install the CT. Open the CT cover, place it on the main "L" cable of the power grid, ensuring the arrow on the CT points in the direction of the power grid, then close the cover. See the figure below.

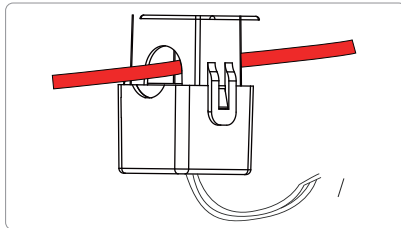
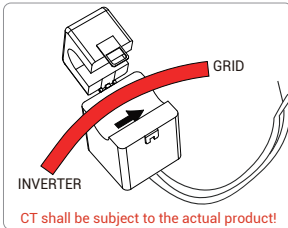

Step 4: Install the electric meter. Select an appropriate location to mount the DIN rail, and install the electric meter on the DIN rail.

Note: Installing the electric meter with a CT involves this step. Electric meter selection:

#### Types of smart meters-1



**01**  
Meter Model:  
DDSU666  
/230V 100A(40mA)  
2P 1CT



**02**  
Meter Model:  
DDSU666  
/230V 100A/40mA  
2P 2CT

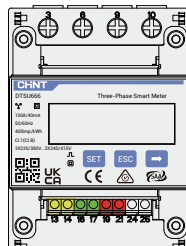

**03**  
Meter Model:  
DTSU666  
/3X230/400V 100A(40mA)  
4P 3CT

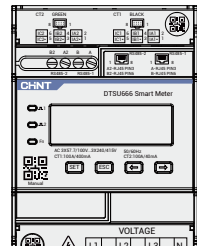

**04**  
Meter Model:  
DTSU666  
/3X230/400V 100A(40mA)  
4P 6CT

Types of smart meters-2



**01'**  
 Meter Model:  
 ADL200N-CT  
 /D10/230V  
 /80A 1CT



**03'**  
 Meter Model:  
 ADL400N-CT  
 /D16/3x230/400V 120A  
 /40mA 3CT

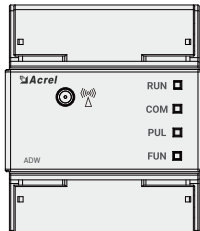

**04'**  
 Meter Model:  
 ADW200-D16-ZS  
 /3x230/380V 100A  
 /20mA 6CT

Definition of Inverter and electric meter RS485 communication interface

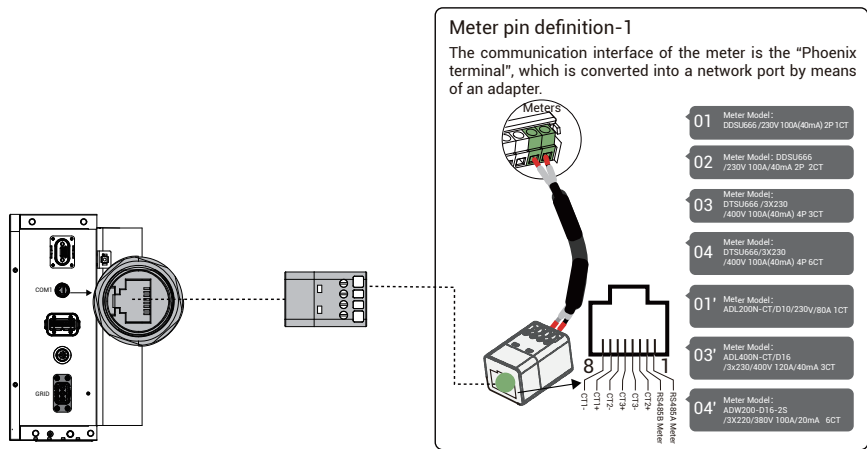

Single Phase Grid + DC couple + CT

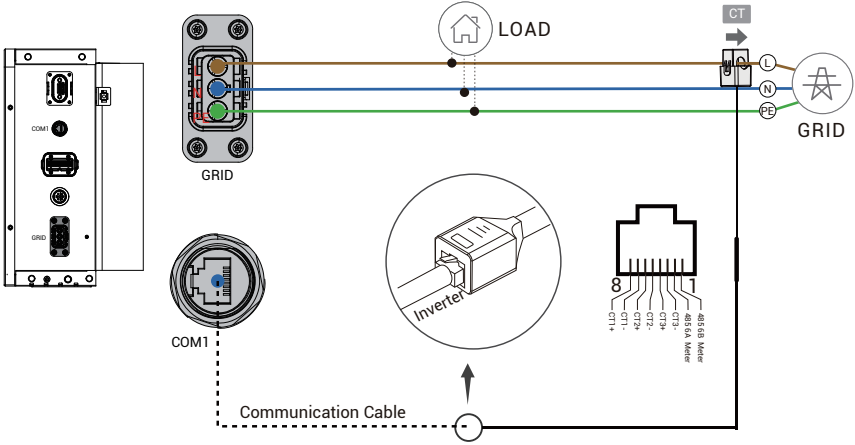

Single Phase Grid + DC couple + Single Phase CHINT or ACREL Meter ( 1 CT )

Single phase ACREL Meter ( 1 CT )

Single Phase ESS Product

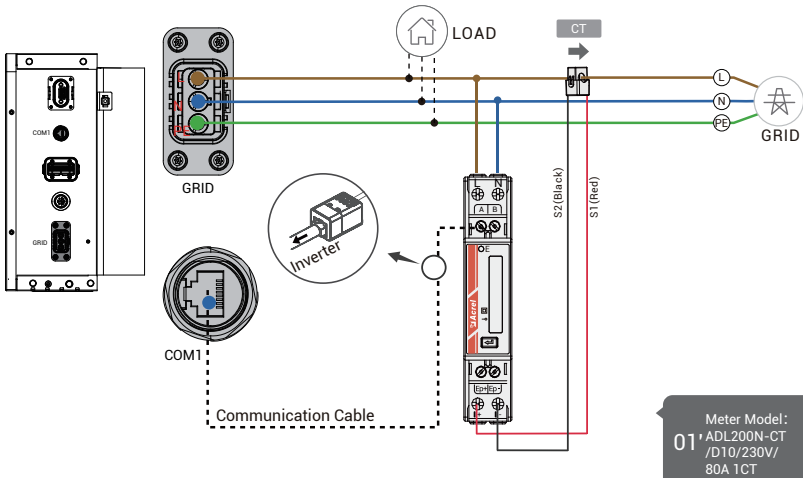

Single Phase CHINT Meter (1 CT)

Single Phase ESS Product

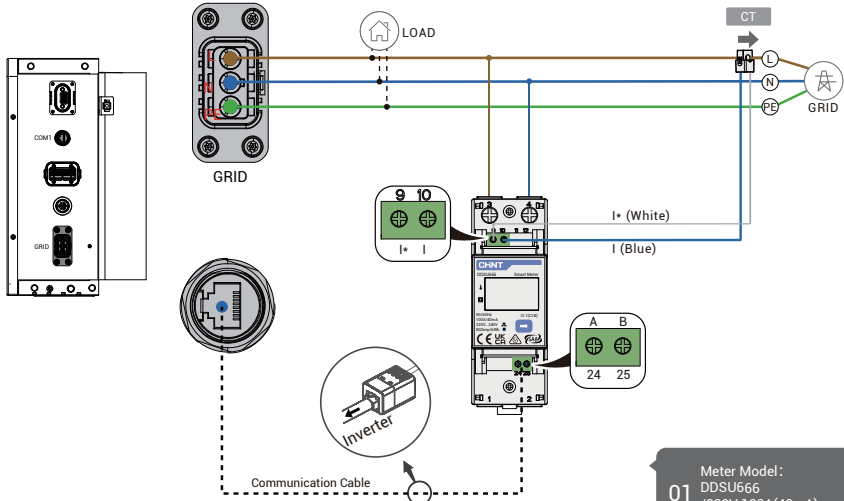

01 Meter Model:  
DDSU666  
/230V 100A(40mA)  
2P 1CT

Single Phase Grid + AC couple (Single Phase Solar Inverter) + Single Phase CHINT or ACREL Meter (2 CT)

Single Phase CHINT Meter (2 CT)

Single Phase ESS Product

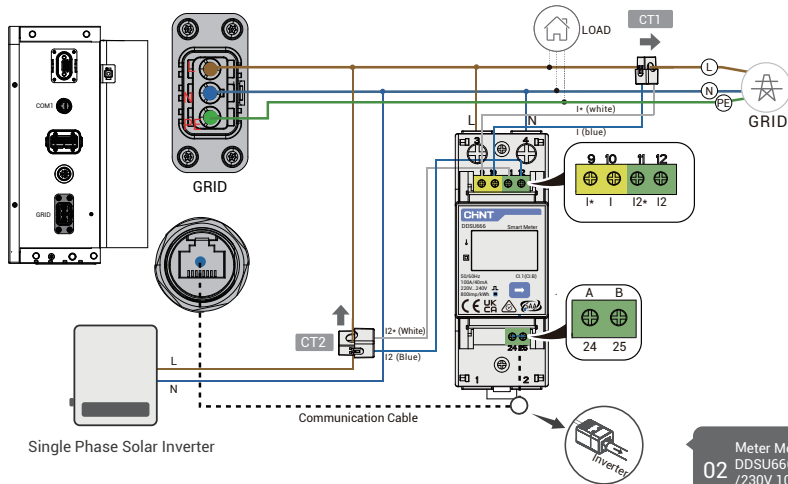

02 Meter Model:  
DDSU666  
/230V 100A/40mA  
2P 2CT

Single Phase ACREL Meter (2 CT)

Single Phase ESS Product

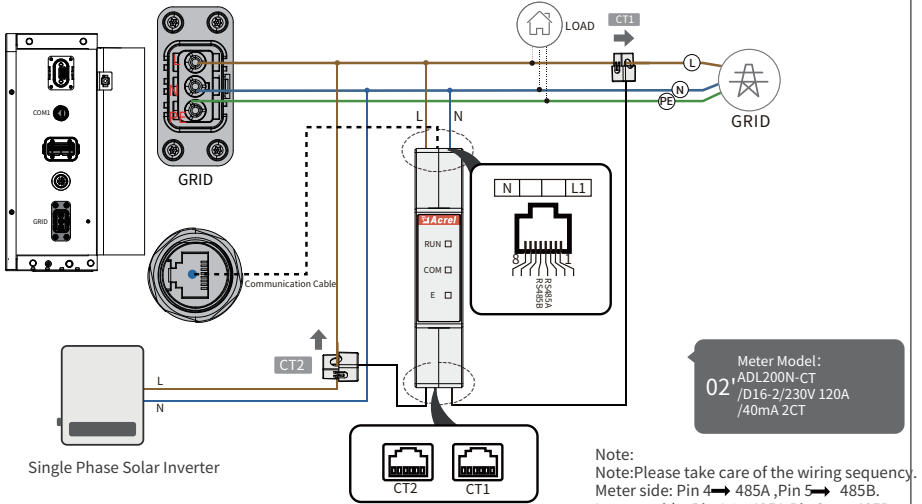

Single Phase Grid + AC Couple (Single Phase Solar Inverter) + Three Phase Meter (3 CT)

Three Phase CHINT Meter (3 CT)

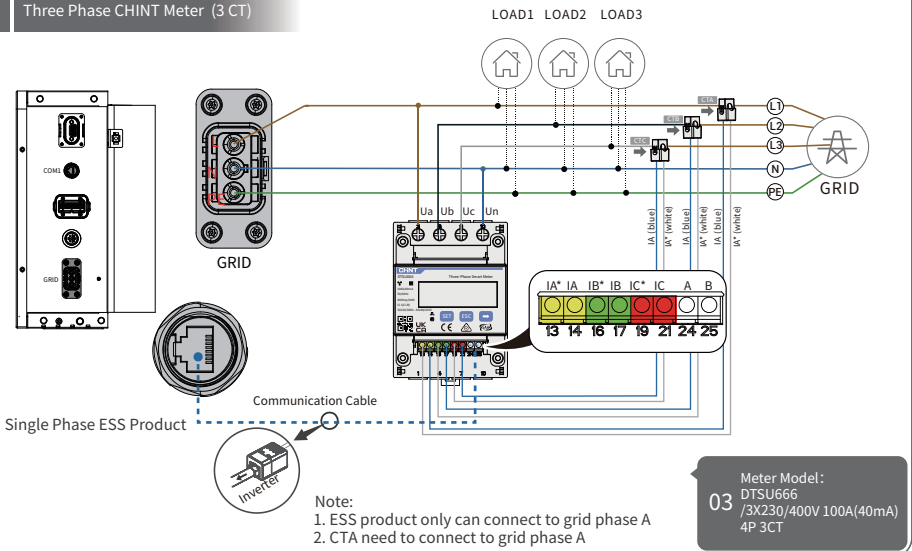

Three Phase ACREL Meter (3 CT)

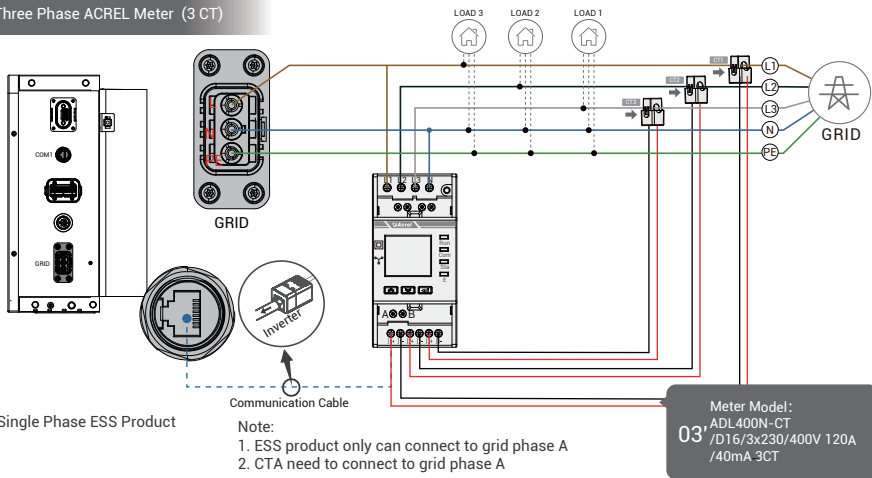

Three Phase Grid + AC Couple (Three Phase Solar Inverter) + Three Phase CHINT or ACREL Meter (6 CT)

Three Phase CHINT Meter (6 CT)

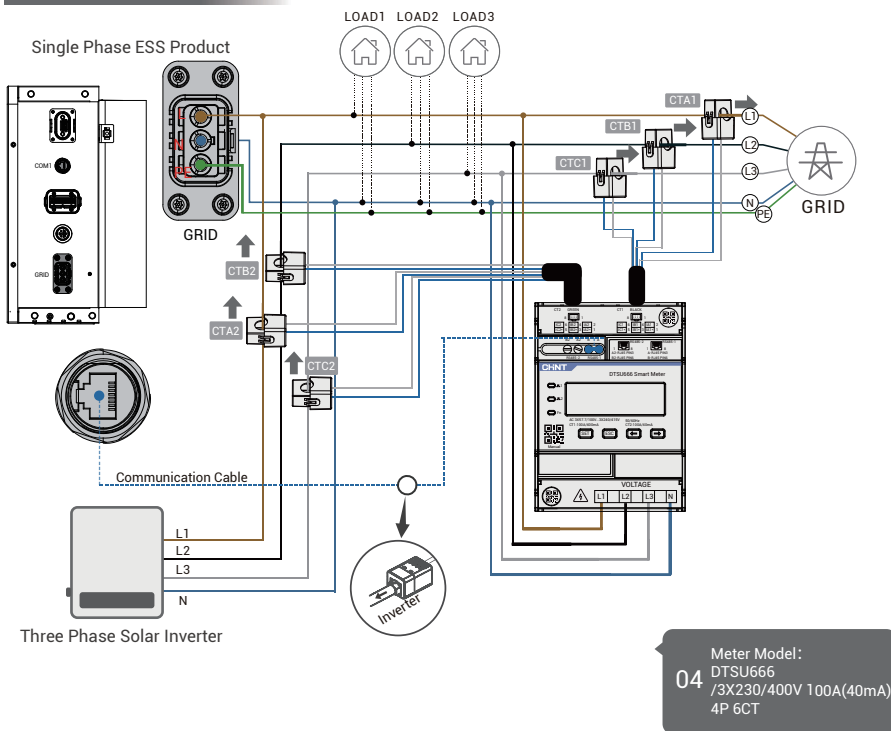

Three Phase ACREL Meter ( 6 CT )

Single Phase ESS Product

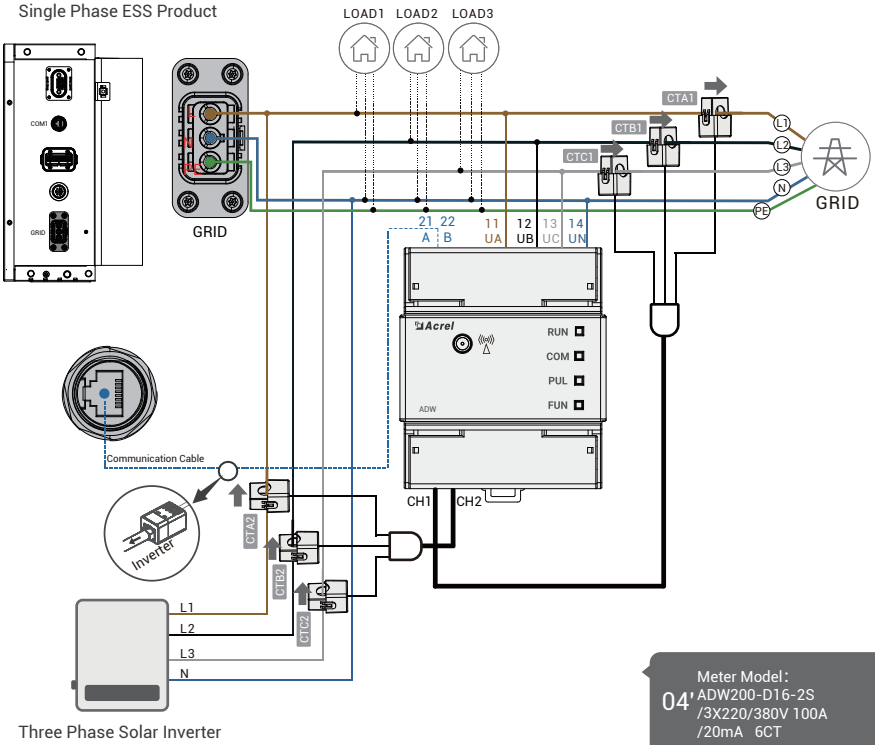

04 Meter Model:  
ADW200-D16-2S  
/3X220/380V 100A  
/20mA 6CT



Notice

- The inverter has not been tested to AS/NZS 4777.2:2020 for multiple inverter combinations and/or multiple phase inverter combinations so combinations should not be used or external devices should be used in accordance with the requirements of AS/NZS 4777.1.
- The neutral continuity shall be maintained for multiple inverter combination connection.

## 6 System Operation



### Warning

- First use requires adjustment and setup by a professional. Improper setup may affect the normal use of the equipment.
- When operating the system, please wear dedicated protective equipment and use insulated tools to avoid short circuits or electric shock.
- Observe the status of the equipment when turning on the system. If any abnormal phenomena occur, immediately shut down the equipment. Seek assistance from a professional, and operate only after the equipment has been inspected and found to be free of abnormalities by the professional.
- When servicing or operating the system, ensure that the battery switch is switched off.

### Startup protection requirements



### 6.1 Power on/off the device



### Warning

- Before starting the system, ensure that the equipment is properly installed and securely fastened.
- Check if the wiring is reasonable and if the connections are good.
- Ensure that the surrounding environment meets the startup requirements.
- After opening the battery pack, it must be installed and powered on promptly. If it cannot be powered on immediately, the battery pack must be returned to its packaging box, ensuring that there is a desiccant inside and the box is well sealed. It should never be left outside for extended periods.

### Power on/off sequence

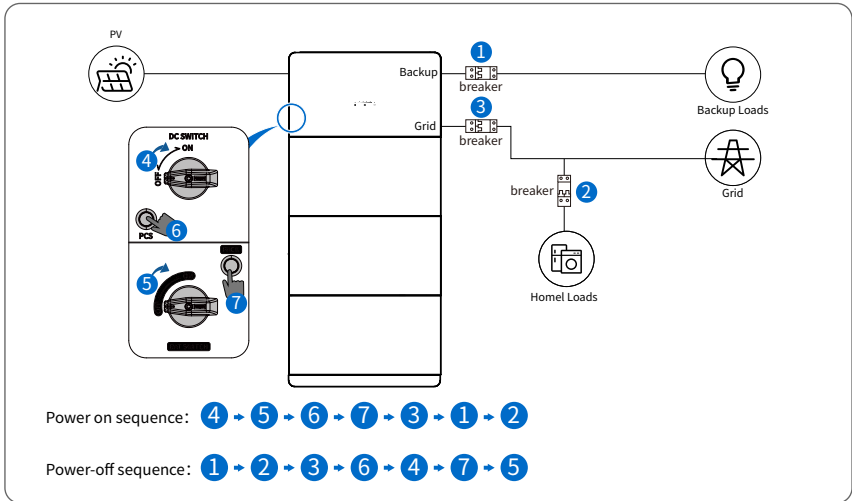

### Circuit breaker specifications

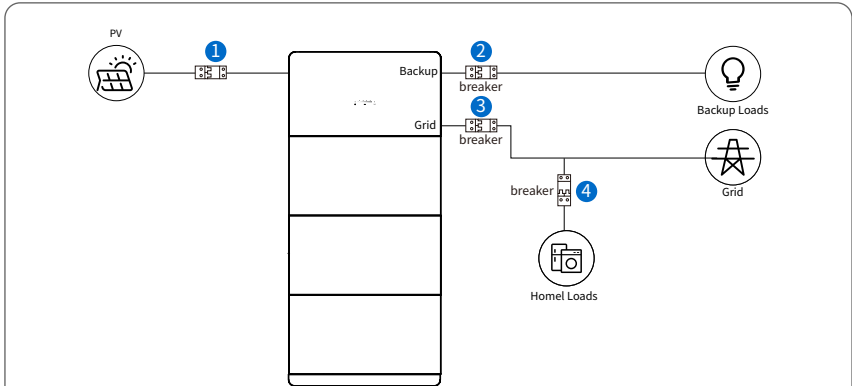

#### Circuit breaker specifications:

Model	①	②	③	④
MEI2-HS3H-AIO	≥32A/≥500V DC Breaker	≥40A/≥230V AC Breaker	≥40A/≥230V AC Breaker	≥40A/≥230V AC Breaker
MEI2-HS3.68H-AIO			≥50A/≥230V AC Breaker	≥50A/≥230V AC Breaker
MEI2-HS3.8H-AIO			≥63A/≥230V AC Breaker	≥63A/≥230V AC Breaker
MEI2-HS4H-AIO				
MEI2-HS4.6H-AIO				
MEI2-HS5H-AIO			≥63A/≥230V AC Breaker	≥63A/≥230V AC Breaker
MEI2-HS5H-AIO2				
MEI2-HS6H-AIO				
MEI2-HS8H-AIO				

## Lock the battery switch

The DC isolator shall be locked when the switch at off position for maintenance. The DC switch shouldn't be lock when the switch is st on position. Refer to the figure below for the locking method

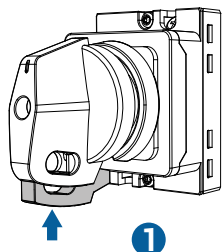

Push up to the position shown in the diagram and ensure the holes are aligned

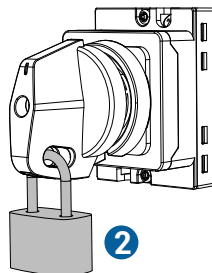

## 7 APP Operation

To learn more about how to use the app, please scan the QR code below to access the user manual.



APP User Manual

### 7.1 APP download and installation

- Mobile phone operating system requirements: Android 5.0 and above, IOS 14.0 and above.
- Search for iEasy in Google Play (Android) or App Store (IOS) to download and install it.

#### Registration & Login

01. When the user installs the app for the first time and launches it, the interface will navigate to the login homepage;
02. Select the service station to be registered and the user role to be registered;
03. When the user selects the installer role, the interface switches to the installer registration page;
04. On the installer registration page, users can choose the organizational relationship, which includes: Newly Joined and Newly Created;

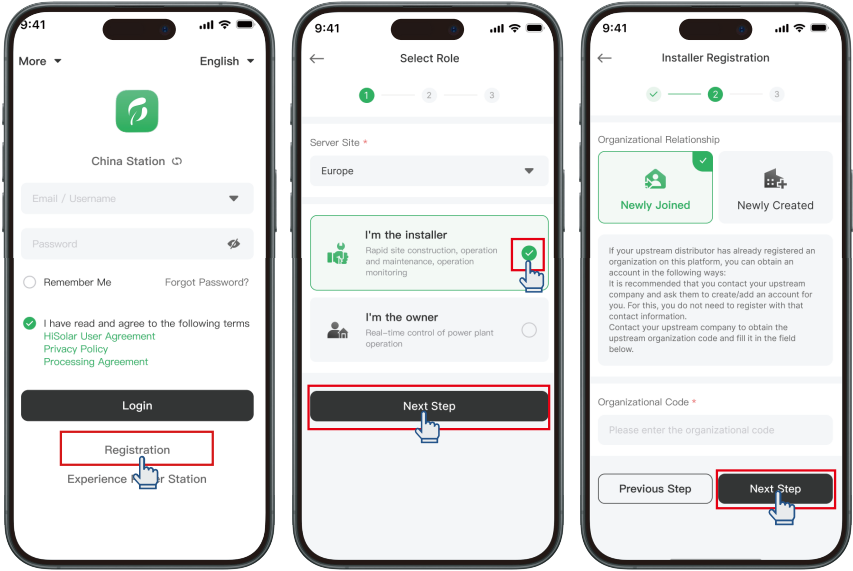

Step 5: After the user completes filling in the registration information and the information is successfully verified, they check the relevant registration agreement to complete the registration.

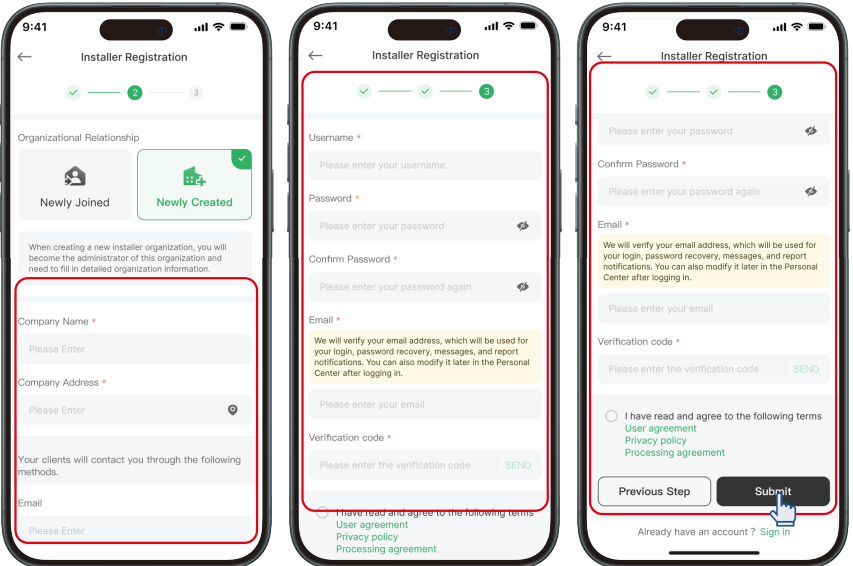

## ✓ Owner Registration:

Step 1: The user selects "I am the owner," and the interface navigates to the owner registration information filling page.

Step 2: After completing the required information and passing the verification, the user checks the relevant agreement to successfully complete the owner registration.

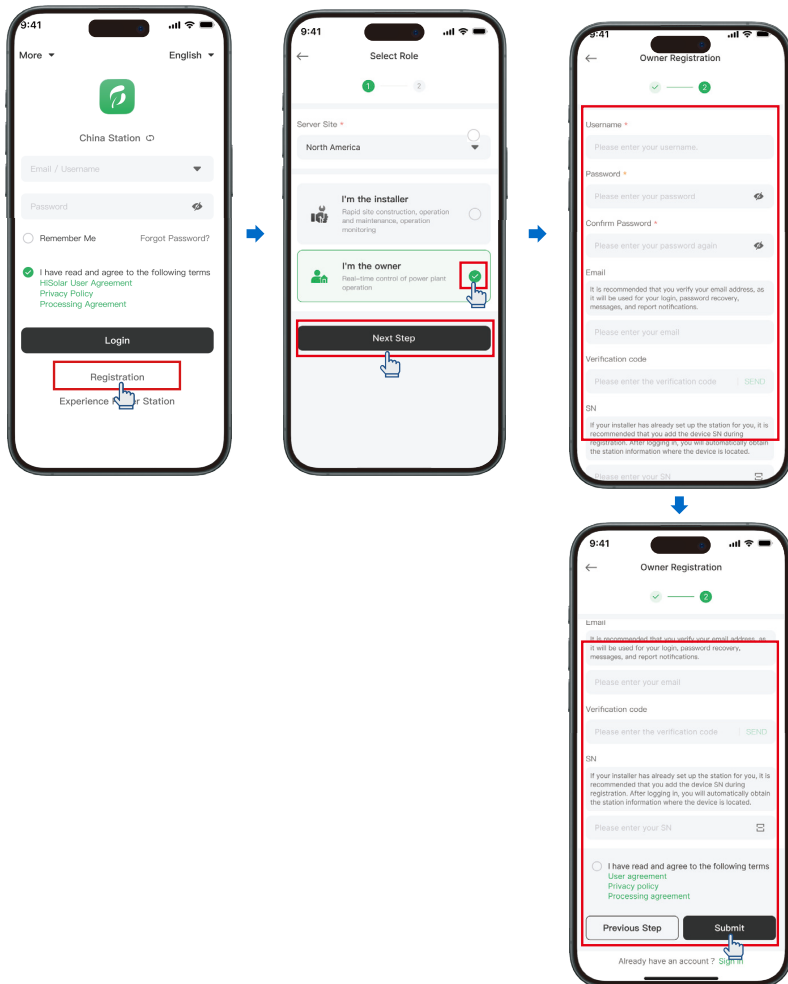

## ✓ User login:

Step 1: When the user registration is completed, you can enter the account and password on the login page, check the relevant agreement description, click the login button, and the login is successful;  
Step 2: Once the login is complete, go to the app's home page.

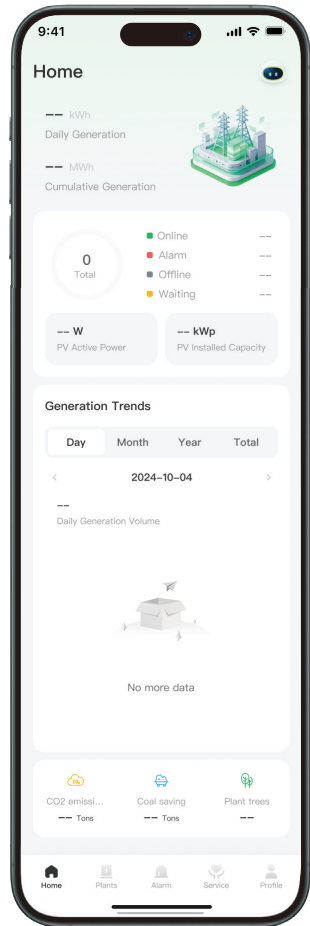
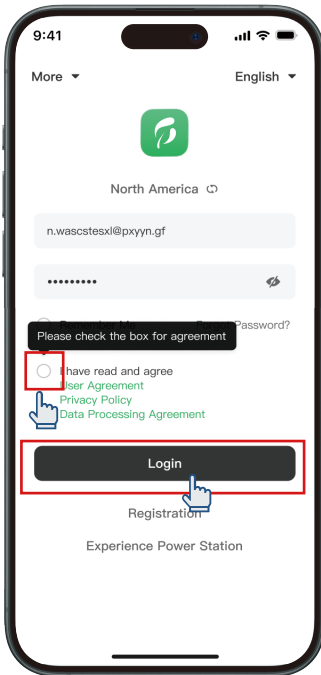

## 7.2 Device Configuration

### • Wifi Configuration(Device means: Inverter)

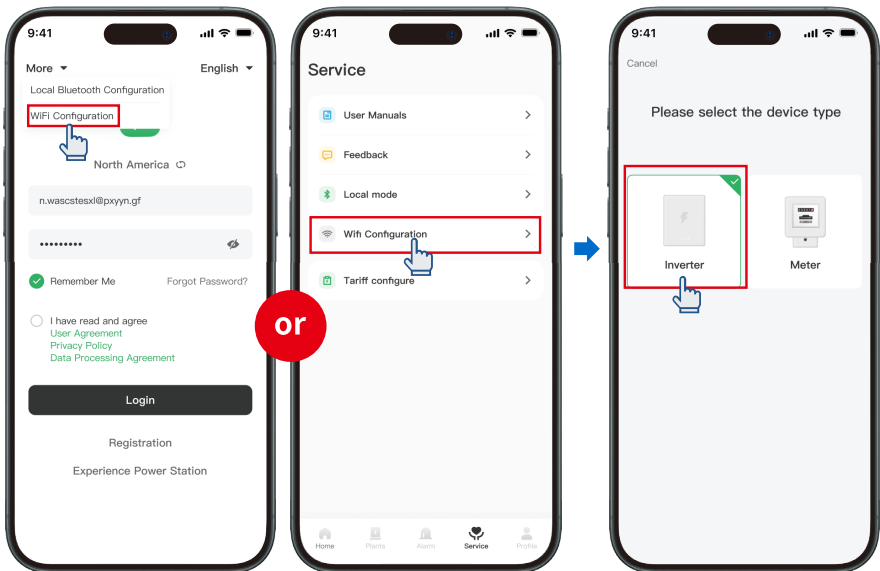

Step 1: Enter WiFi Configuration

(Entry 1: If not logged in, launch the iEasy App, and click "More - WiFi Configuration" in the top left corner of the login page.

Entry 2: If already logged in with an account, click "Service - WiFi Configuration" in the bottom tab bar of the App.)

Step 2: Select Device Type: Inverter.

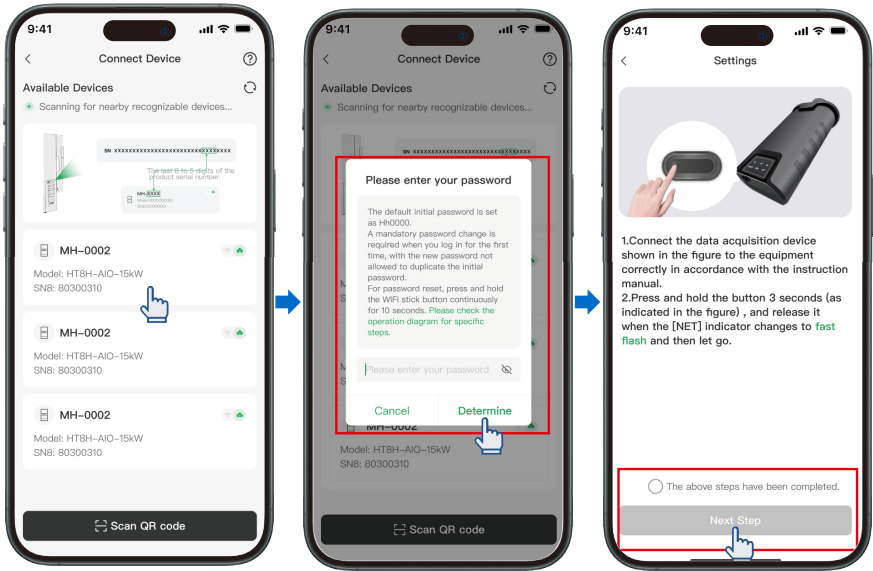

Step 3: The interface navigates to the device connection page, where the user can view nearby identifiable Inverter devices.

Step 4: Identify the Inverter device by its SN serial number and click the arrow button.

Step 5: After clicking the arrow button, the user connection password interface pops up (default connection password: Hh0000). If the user enters the correct password, they proceed to the next interface. Clicking "Cancel" will cancel the connection.

Step 6: Press and hold the button shown in the image for more than 3 seconds. Release it after seeing the indicator light flash rapidly, check the "Above operations completed" button, and click "Next Step."

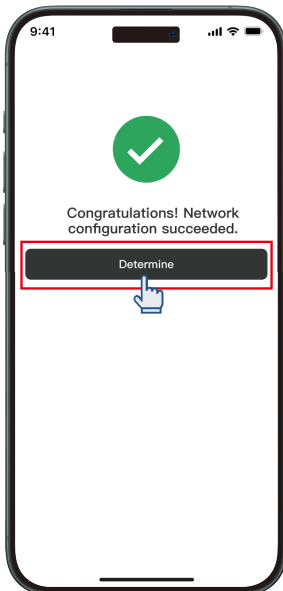
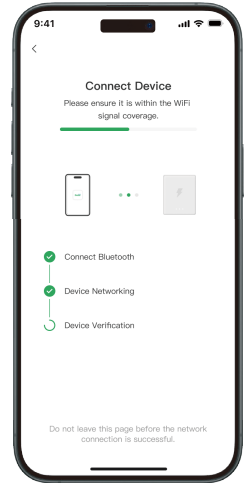
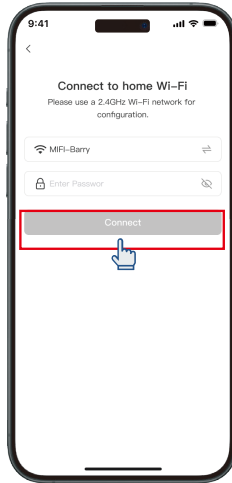
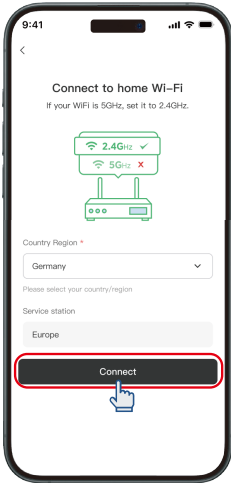

Step 7: After selecting the country or time zone, the user chooses a WiFi name and manually enters the WiFi password to connect to the home wireless network. Click "Connect" to proceed to the device connection step. Do not leave the current page until the network connection is successful.

Step 8: After the connection is successful, the interface prompts that the network configuration is successful.

### 7.3 Local Bluetooth Configuration

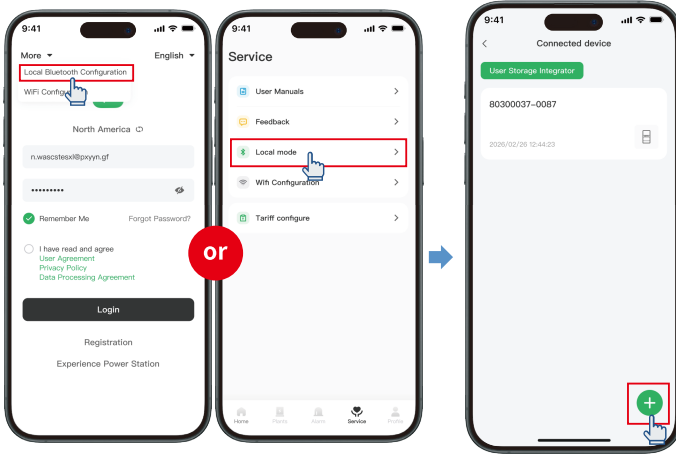

Step 1: Enter Bluetooth Configuration

(Entry 1: If not logged in, launch the iEasy App, and click "More - Local Bluetooth configuration" in the top left corner of the login page.

Entry 2: If already logged in with an account, click "Service - Local Mode" in the bottom tab bar of the App.)

Step 2: Click the "+" button on the interface to enter the Bluetooth direct connection interface.

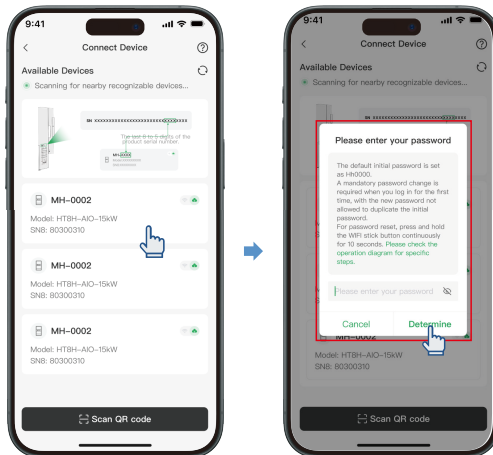

### 7.3.1 Viewing System Data on the App

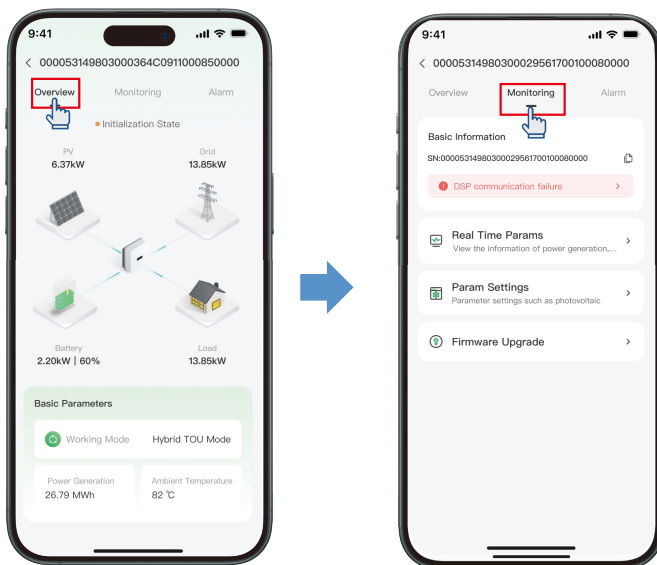

After entering the device details page, users can view system data, alarms and other information in the device details page;

- 1) On the overview interface, you can view the energy flow diagram and view the energy flow of the device;
- 2) The monitoring interface shows real-time parameters, full parameter setting entrances, internal debugging parameter entrances, etc.;
- 3) You can view detailed device alarm data in the data list displayed in the Alarm tab.

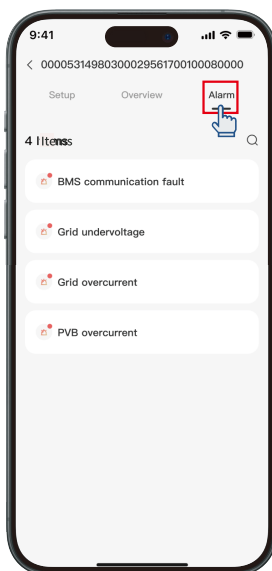

## 7.4 Create a Plant

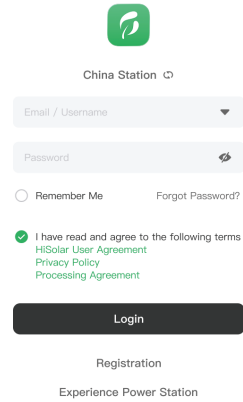

Step 1: The user enters the username and password and logs into the system;

Step 2: On the Plant List page, users can click the "+" button in the bottom-right corner;

Step 3: On the Create Plant page, the user inputs the relevant field information and can configure the power station's electricity price information. After passing validation, the user clicks the save button;

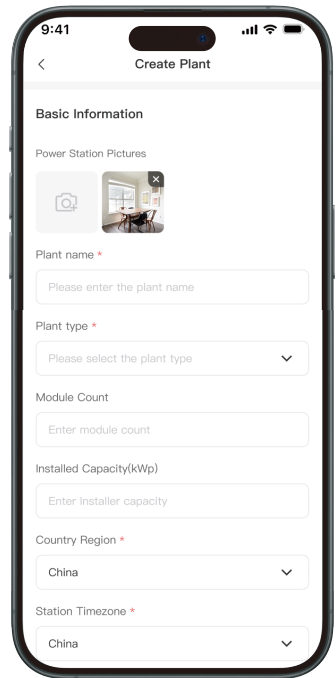
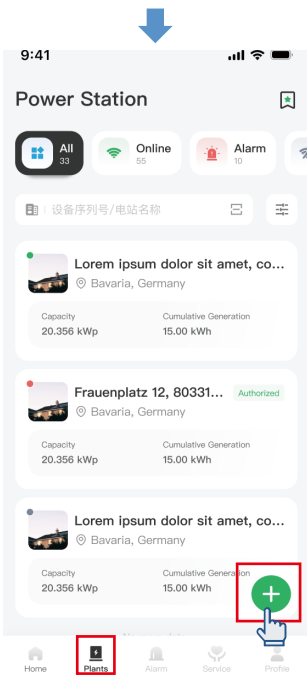

Step 4: After completing the form, the interface prompts that the power station has been successfully created. The user can choose to add devices immediately or add them later.

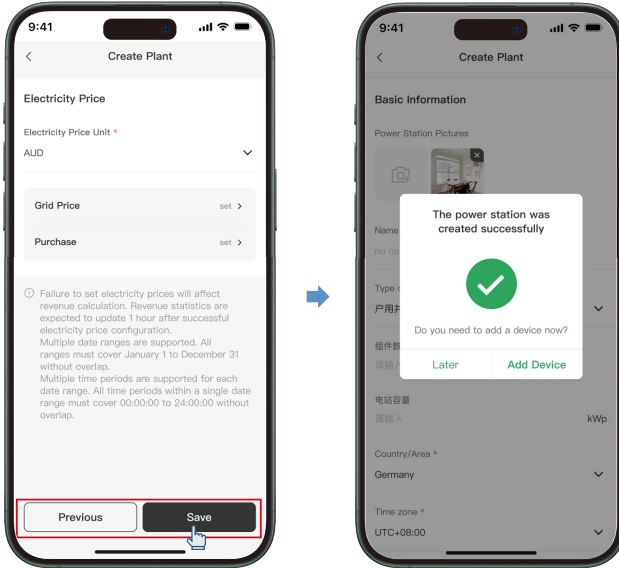

## 7.5 Single Power Station Page

### 7.5.1 Single Power Station Page - Overview

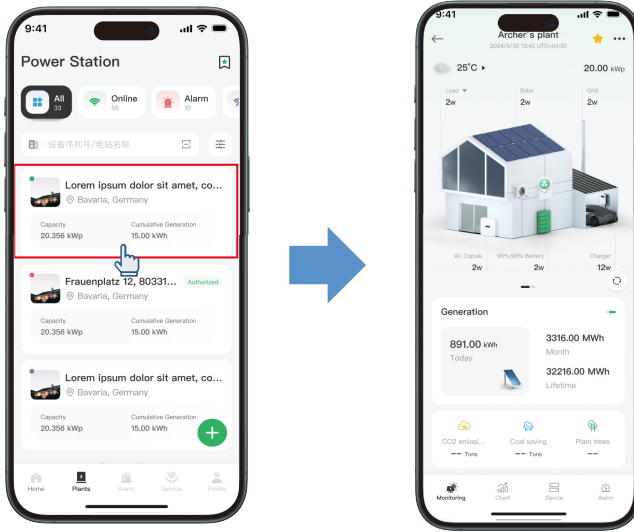

Users click on the list of plants to enter the interface of a single plant; On the single-plant interface, users can view the energy for energy storage scenarios volume flow diagram, power generation, environmental contribution index; Among them, the energy flow diagram can view the energy flow of PV, battery, power grid, and load;

## 7.5.2 Statistical Analysis of the Single Plant Page - Curve

On the single plant page, users can click the Curve Analysis tab to view power generation statistics, electricity consumption statistics, power storage statistics, revenue statistics, etc., as shown in the following figure:

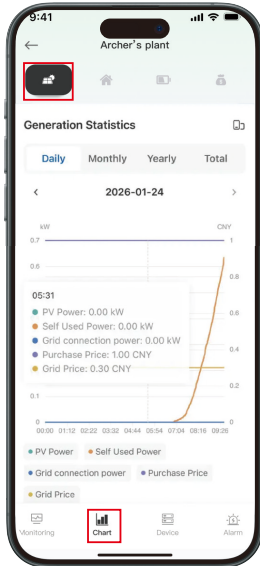

### · Power Generation Statistics:

Daily dimension: photovoltaic power generation power, self-consumption power, power grid sales power;  
 Monthly/yearly/total dimensions: photovoltaic power generation, self-generated and self-consumed electricity, and electricity sold by the grid;

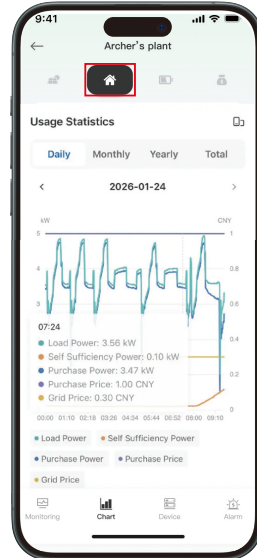

### · Electricity Consumption Statistics:

Daily dimension: load power consumption, self-sufficiency power, grid power purchase power;  
 Monthly/yearly/total dimensions: load electricity consumption, self-sufficient electricity consumption, and power grid power purchase

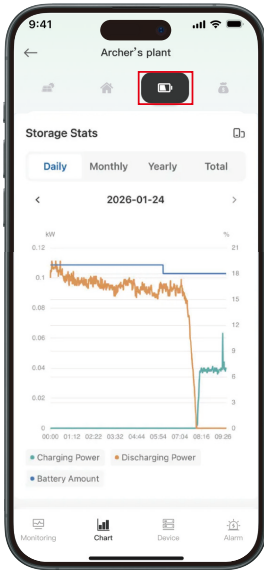

**Electricity Storage Statistics:**

Daily dimension: battery power, charging power, discharge power;  
Month/Year/Total dimensions: Charging capacity, discharging capacity;

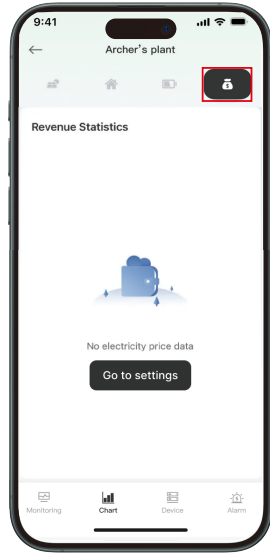

**Earnings Statistics:**

Day/Month/Year/Total dimensions: self-consumption income, electricity sales income.

### 7.5.3 Single Plant Page - List of Devices

On the single plant page, users can click the device list tab to view the devices bound to the plant. The interface provides an entrance to add a device, supports device search, and clicks on the device list to enter the device details interface:

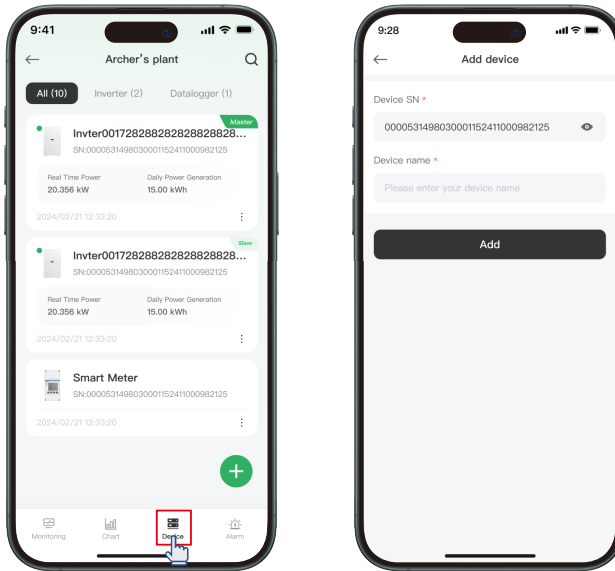

### 7.5.4 Single Plant Page - Equipment Replacement

Operating instructions for equipment replacement (equipment means: inverter):

1. The replaced inverter will not be able to be added to the plant again;
2. Please carry out the replacement operation of the same type of equipment, otherwise the replacement will fail;
3. After equipment replacement, the new equipment will not inherit the data of the original equipment, and the cumulative power generation of the plant will still include the power generation of the original equipment;
4. You can click the 'Replacement History' button in the device management interface to view the device replacement history;

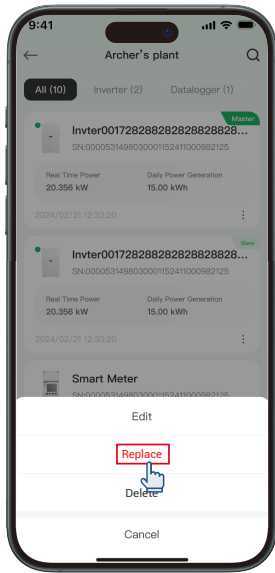

1) Users can click on the Replacement operation in the Single Plant Page - Device List;

2) After clicking Replacement, the interface enters the Replacement device interface, in the Replacement device interface, it displays the original device information, supports the user to add the replacement device, and requires the user to tick the device Replacement operation instructions to complete the Replacement operation;

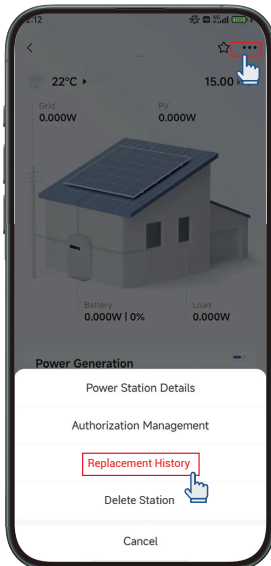
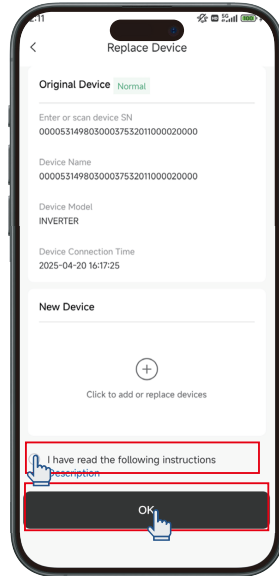

3) On the single plant page, by clicking on the button in the upper right corner, the user can click on the Replace History - tory drop-down item;

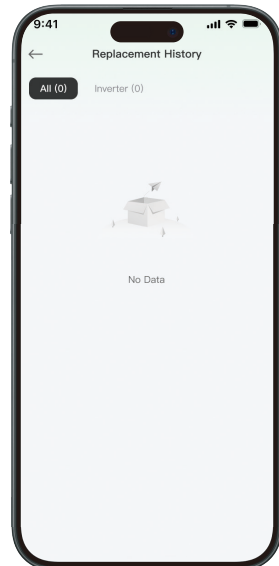

4) Click Replacement History to view the device replacement history. In the device history interface, you can view the original device & new device information and replacement time and other information;

### 7.5.5 Single Plant Page - Alarm List

On the single plant page, users can click the Alarm tab to view the alarm data of the devices in the plant, and provide alarm search and alarm filtering functions in the alarm list:

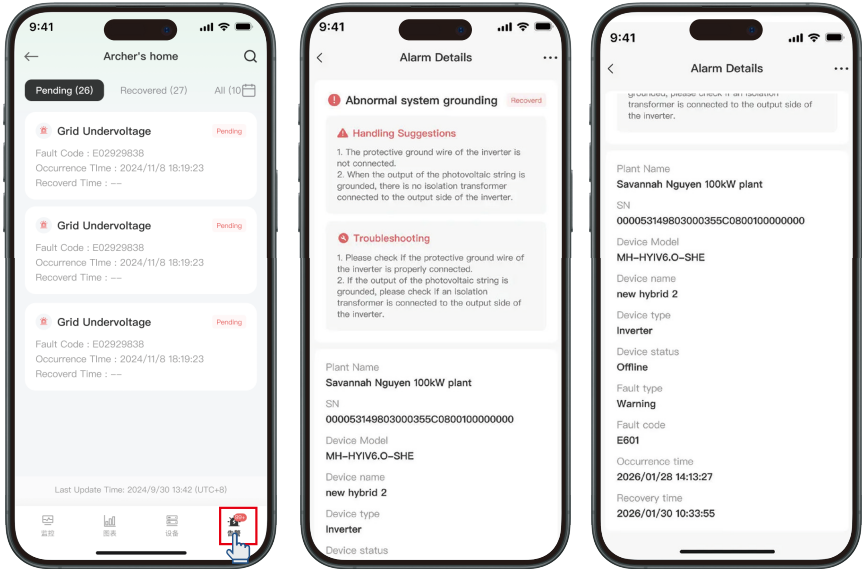

NOTE: The inverter is equipped with a ground fault alarm function. Once a ground fault occurs, the system will issue an alarm to take corrective measures; the alarm will notify the user through push notifications and messages; before the fault is resolved, the alarm will be displayed in the active fault list.

## 7.6 Adding Devices

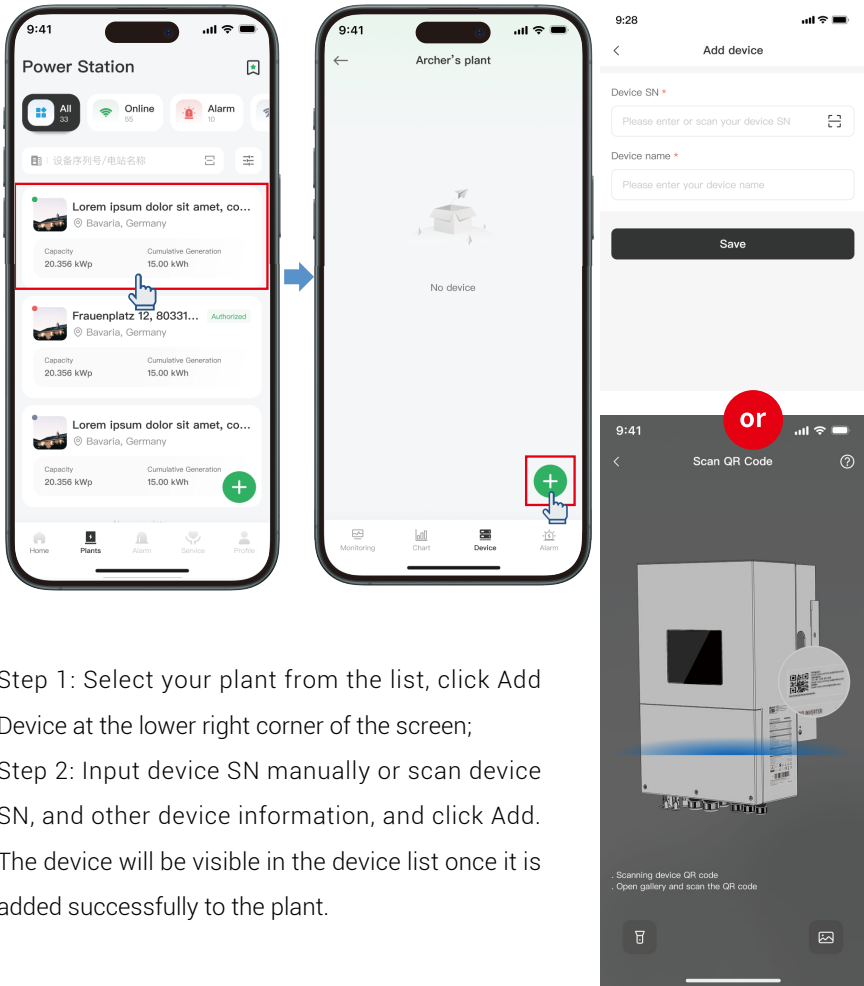

## 7.7 Device Remote Control

- 1) The user clicks on the device list, and the interface jumps to the device details interface;
- 2) In the device list interface, users can click the settings button, and the interface jumps to the settings interface;

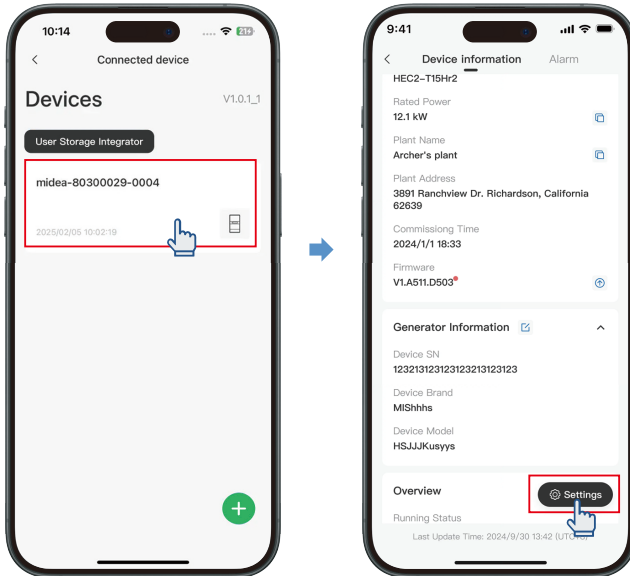

3) You can view detailed device alarm data in the data list displayed in the Alarm tab.

4) The user enters the setting interface, and the interface parameters are read-only and cannot be modified by operation settings.

The content that can be viewed only includes:

Contains information for viewing inverter settings after commissioning including:

- Country Grid Code/Region settings
- Power quality response modes settings
- Grid Protection settings Inverter firmware version

The following settings are protected by the password and only installers can obtain the password and change these settings.

Contains information for commissioning inverter including:

- Selecting Australia Region A/B/C for grid protection settings and power quality response modes settings
- Adjusting grid protection settings and power quality response mode setpoints

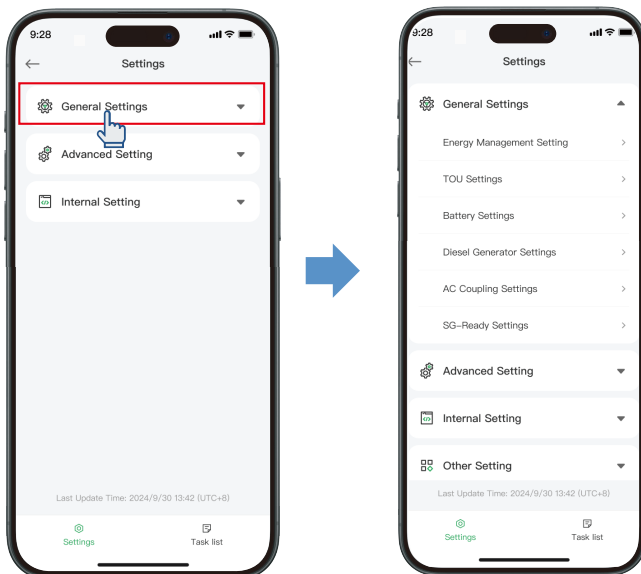

- The following operation is the APP settings page for grid protection settings and power quality response settings.

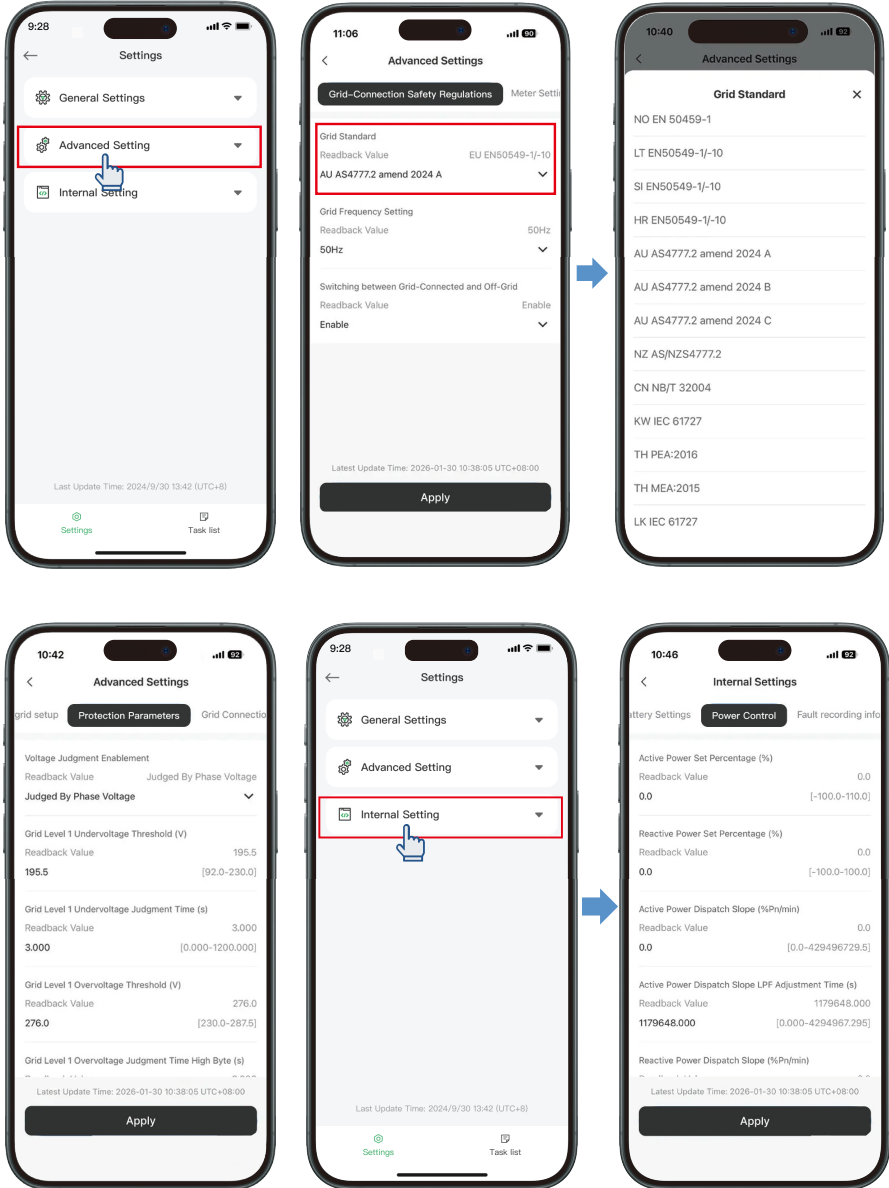

## 7.8 Quick Settings



### Notice

If network provisioning has already been completed, please skip Steps 1~4 in the quick setup and start from Step 5.

Step 1: The user opens the iEasy app and clicks on the WiFi configuration button;

Step 2: On the WiFi configuration interface, click the arrow button;

Step 3: Enter the connection password: Hh0000, click on connect;

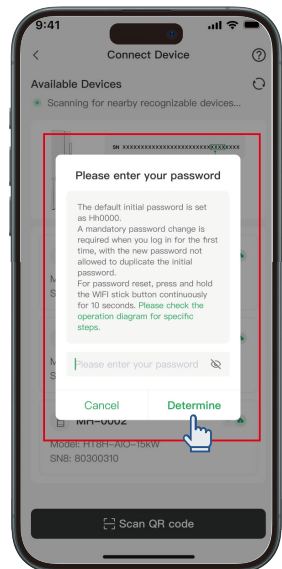
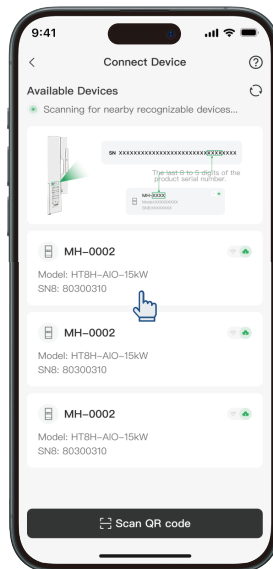
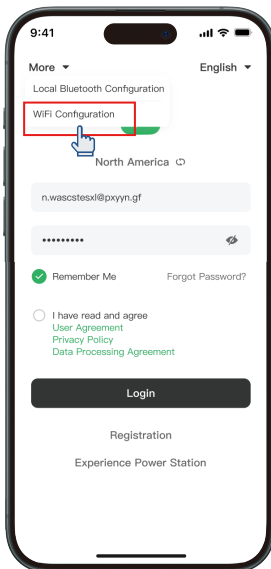

Step 4: After successful connection, enter the device list interface and click on the device list;

Step 5: The user enters the device monitoring interface and clicks on the monitoring tab;

Step 6: On the monitoring parameter interface, click on the Param Settings entrance;

Step 7: Enter the Param Settings interface and click on the Quick Setup entrance:

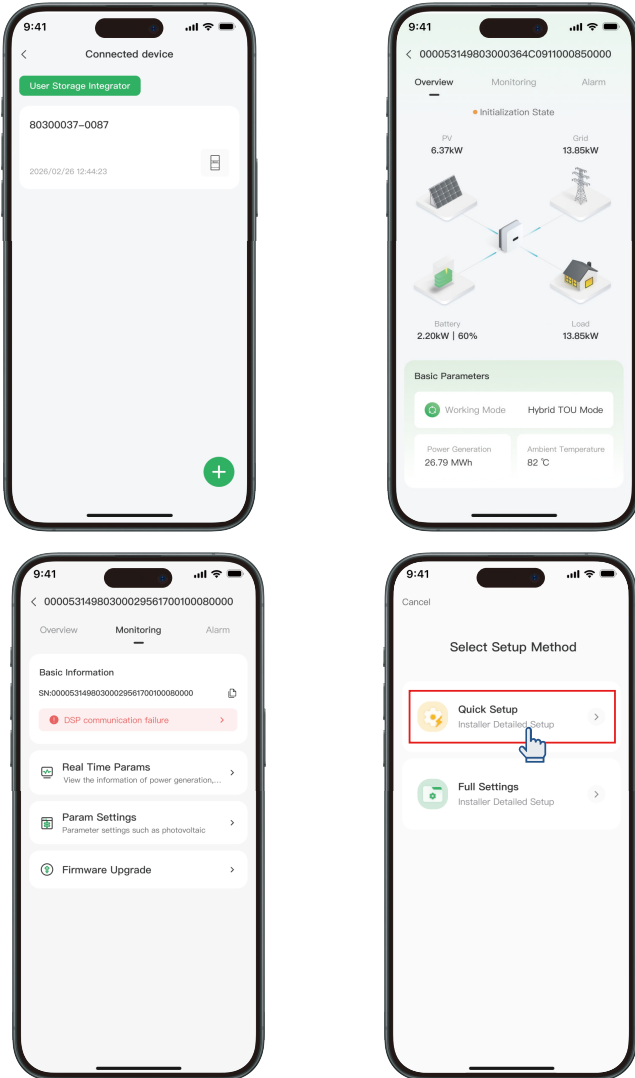

Step 8: Enter the quick settings interface, where users can quickly set parameters. There are a total of 4 steps to complete the device parameter configuration operation; Step 9: During the quick setup process, users can switch between the next and previous steps, perform parameter modification operations, and click the "Finish" button to complete the device parameter configuration operation;

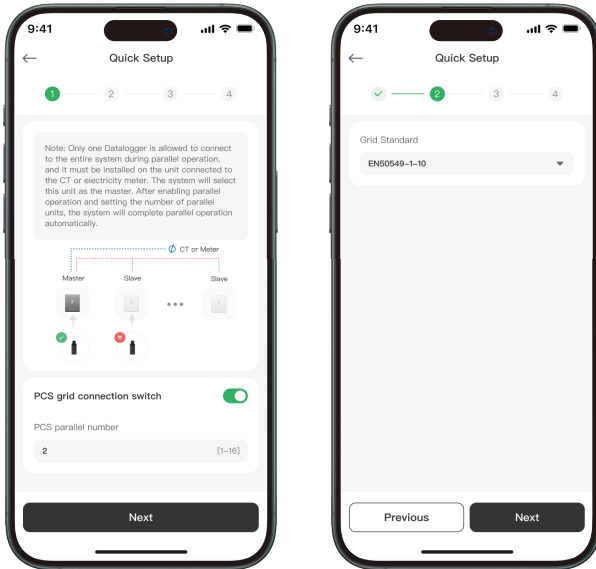

**NOTE:** The App provides two quick setting entrances, namely: after the network configuration is successful, the interface pops up the quick setting entrance, the local Bluetooth monitoring interface - parameter setting - quick setting entrance; The quick setting takes a total of four steps, and the point command is issued separately;

**Step1:** First determine whether it is a parallel system, after the parallel switch is enabled, fill in the number of parallels, if it is a parallel scenario, the equipment parameters are issued to the equipment for execution through broadcasting, and multiple devices execute the same parameter instructions;

**Step2:** Configure the grid security code and three-phase phase sequence configuration, in which the single camera is not displayed;

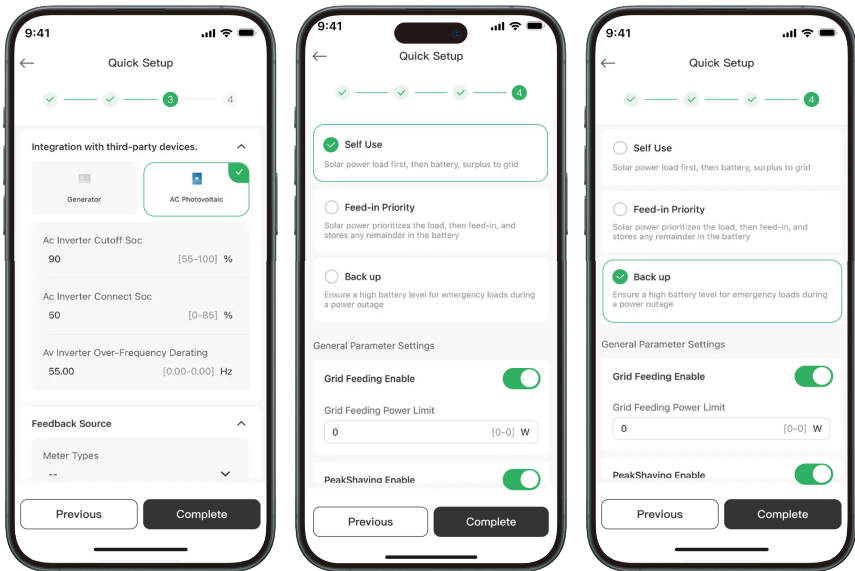

**Step3:** Select the third-party equipment: generator, AC Couple, intelligent load, feedback source settings, need to be enabled before the relevant parameter setting operations can be carried out, of which the feedback source settings are: meter settings, CT settings, etc.; The three third-party devices connected to the inverter are generators by default; choose one of the three and do not support coexistence;

**a:** When the generator is selected, the generator enable switch needs to be turned on, and the settings are supported: diesel generator rated power, battery charging power limit, generator control mode (automatic mode/manual mode), diesel generator maximum input power; If it is in manual mode, it supports the following settings: automatically start the minimum SOC of the diesel generator, stop the maximum SOC of the diesel generator, and the cooling time of the diesel generator; Among them, the split machine supports setting: automatic start of the minimum battery voltage of the diesel generator, the maximum stop voltage of the diesel generator;

**b:** When AC Couple is selected, it supports setting: AC photovoltaic inverter disconnects SOC, AC photovoltaic inverter connects to SOC, AC photovoltaic inverter overfrequency and load reduction frequency setting, if the battery type is: lead-acid battery, then the split machine supports setting: AC photovoltaic inverter disconnects the battery voltage, AC photovoltaic inverter connects to the battery voltage;

**c:** When the smart load is selected, it supports the following settings: smart load grid-connected always-on switch, smart load unavailable battery SOC, smart load available battery SOC; If the battery type is: lead-acid battery, then the split machine supports setting: intelligent load unavailable battery voltage, intelligent load available battery voltage;

**d:** The feedback source is set to: meter setting, CT setting (CT direction, CT ratio), if the meter type is built-in CT, it supports configuring CT ratio parameters;

**Step4:** Set the user scenario, support settings: anti-reverse flow mode, power sales priority mode; When the user selects the anti-reverse current mode and the feed enable switch is set to: Allow to sell power, the user is supported to set: feed power limit value, and when the Grid Peak-shaving switch is enabled, it is supported to set: Grid Peak-shaving power limit; When selecting a battery, it supports settings: the power grid allows charging the battery, the maximum power of the grid charging the battery, the number of battery packs is set, etc.; secondly, TOU is enabled by default, and the App interface is not displayed, if users need to set TOU-related parameters, they can modify the parameters by remote control or local Bluetooth.

\* The fourth step of the quick setup may vary depending on different software versions; the actual display is subject to the software version of the device:

As shown in Figure 1: Set user scenarios, supporting settings such as reverse power flow prevention mode and sell-to-grid priority mode. When the user selects the reverse power flow prevention mode and the power feed enable switch is set to "Allow selling electricity," the user can set the power feed limit value. When the Grid Peak-shaving switch is enabled, the Grid Peak-shaving power limit value can be set. When a battery is selected, settings such as allowing the grid to charge the battery, maximum grid-to-battery charging power, and the number of battery packs can be configured. Additionally, TOU (Time of Use) is enabled by default and is not displayed on the app interface. If users need to adjust TOU parameters, they can do so via remote control or local Bluetooth parameter modification.

As shown in Figure 2: Users can set operation modes including self-consumption, sell-to-grid priority, and battery backup.

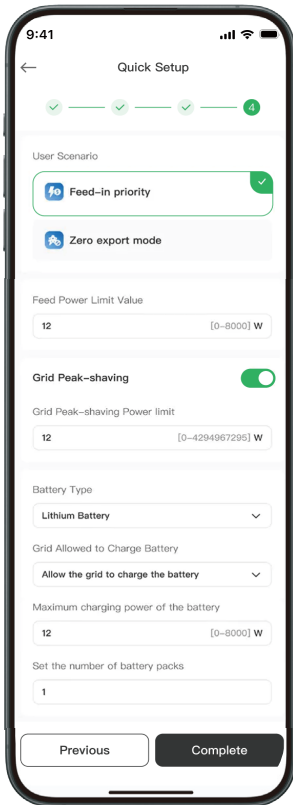

Figure 1

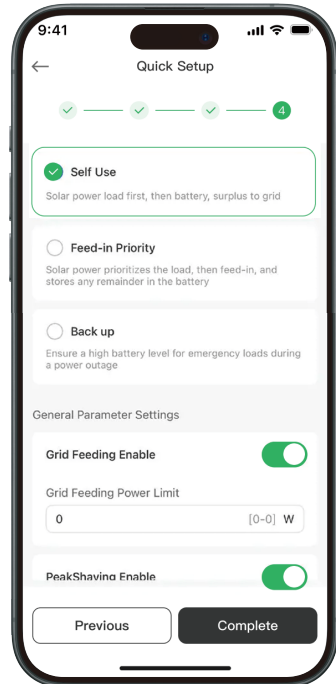

Figure 2

## 8 Maintenance and Troubleshooting

### 8.1 Pre-operation Maintenance

- Before the product is put into use, read the manual carefully and connect and install the device strictly according to the instructions in the manual.
- Carefully check whether the parts and terminals have been loosened or detached during transport.
- Carefully check whether each wire diameter meets the requirements; whether the insulation is good; whether the system grounding is in accordance with the insulation regulations.

**CAUTION:** When using the inverter, operate it in strict accordance with the instructions for use and maintenance, and the warning signs on the equipment should be kept intact. Equipment maintenance is strictly prohibited during operation.

### 8.2 Maintenance during operation

- Check the equipment wiring regularly to make sure it is firm, and check whether the dust screen, fan, power module, terminals and other parts are working properly.
- When there is high voltage inside the inverter cabinet, you should usually pay attention to check whether the cabinet door is locked.
- When the room temperature exceeds 30 °C, effective cooling measures should be taken to prevent overheating and burning.
- The structure and electrical connection of the equipment should be kept in good condition, and there should be no corrosion and dust accumulation. There should be no big vibration and abnormal noise when the equipment is running.
- Periodically disconnect the circuit breaker on the AC output side of the equipment once.
- When the DC bus capacitor temperature is too high or exceeds the service life, it should be found and replaced in time.
- The equipment belongs to high reliable operation equipment, which can achieve long-term trouble-free operation, and should be inspected on working days to hear whether the sound is normal or not, whether there is any debris on the outside, whether the air vent accumulates dust or not, whether the panel display is normal or not, and whether any problem is found should be dealt with and reported in a timely manner.

**Note:** Non-professionals are not allowed to disassemble and overhaul without permission. The equipment usually has short circuit, over-current, over-voltage, overheating and other automatic protection functions.

There is no need to manually switch off the device when problems occur.

## 9 Fault Information

### a. Grid Side

Fault Code	Fault Name	Handling Method
E100	No AC Connection	1.If it occurs occasionally, it may be due to a temporary power outage on the grid. The inverter will resume normal operation after detecting that the grid has returned to normal, without requiring manual intervention; 2.Check if the AC lines or AC switch are disconnected; 3.The alarm will automatically clear after the grid power supply is restored. 4.After-sales service can use the LCD screen or EMS to view backend data for analysis, or record the data and send it to R&D for analysis;
E101	Grid voltage abnormal	1.If it occurs occasionally, it may be due to a temporary abnormality in the grid. The inverter will resume normal operation after detecting that the grid has returned to normal, without requiring manual intervention. 2.If it occurs frequently, check whether the grid voltage is within the allowable range. If not, contact the local electricity operator. If it is, the grid voltage protection point should also be modified with the consent of the local electricity operator. 3.If it cannot be restored for a long time, check whether the AC side circuit breaker and output cables are connected properly. 4.The execution of safety regulations can use a custom setting instead of the local country code. Use the '50Hz' or 'Custom 60Hz' country code, and set the parameters according to actual requirements, such as protection threshold values, based on the local power grid's actual conditions. (The above operations do not meet local regulatory requirements and should be used with caution) 5.After-sales service can use the LCD screen or EMS to view backend data for analysis, or record the data and send it to R&D for analysis;
E102	Grid frequency abnormal	1. If it occurs occasionally, it may be due to a short-term anomaly in the power grid. The inverter will resume normal operation after detecting that the grid has returned to normal, without the need for manual intervention. 2. If it occurs frequently, please check whether the grid frequency is within the permissible range. If not, please contact the local electricity operator. If it is, you also need to modify the grid frequency protection point after obtaining approval from the local electricity operator. 3. For the implementation of safety regulations, you can opt not to use the local country code, and instead choose to use 'Custom' '50Hz' or 'Custom 60Hz' country code, setting the parameters according to actual requirements. (The above operations do not meet local regulatory requirements and should be used with caution) 4. After-sales service can use the LCD screen or EMS to view backend data for analysis, or record the data and send it to R&D for analysis;
E103	Grid phase sequence is error	<b>Checking:</b> 1. This alarm applies only to three-phase models; 2. Confirm whether the three-phase sequence of the power grid is reversed; <b>Action:</b> 1. Use the LCD screen or APP to set the phase sequence to reverse (this setting defaults to reverse use, and if there is a motor load, the impact of reverse sequence on the motor's direction of rotation must be considered); 2. Or reconnect the power grid wiring correctly;

E104	Output DCI over-range	<p>1.If the anomaly is introduced due to external faults, the inverter automatically resumes normal operation once the fault disappears, without requiring human intervention.</p> <p>2.When the signal sampling circuit has an abnormality causing the DC component to be excessively high, this fault is a hardware issue that cannot be resolved through on-site troubleshooting and requires reporting to R&amp;D for handling;</p> <p>3.After-sales service can use the LCD screen or EMS to view backend data for analysis, or record the data and send it to R&amp;D for analysis;</p>
E105	Anti-backflow over-limit fault	<p>1. If using a meter, set the feedback source to the meter; if using a CT, set the feedback source to the CT, and settings must correspond one-to-one;</p> <p>2. If using a meter, ensure that the meter signal line is properly connected, the communication line is not loose, and the meter's CT is installed correctly (not connected, reversed, disconnected, or misaligned);</p> <p>3. If using a CT, ensure that the CT wiring is not loose and the CT is installed correctly (not connected, reversed, disconnected, or misaligned);</p> <p>4. After-sales can use the LCD screen or EMS to view backend data for analysis, or record the data and send it to R&amp;D for analysis;</p> <p>5. If the issue persists, please contact the dealer / our company customer service center.</p>
E106	Meter or CT abnormal	<p>Troubleshooting:</p> <ol style="list-style-type: none"> <li>1. Please check if the CT or meter CT signal wire connections are normal;</li> <li>2. Please check if the meter CT communication wire is normal;</li> <li>3. Please check if the CT or meter CT is connected in reverse;</li> <li>4. Please check if the CT or meter CT has tripped;</li> <li>5. Please check if the CT or meter CT is incorrectly connected (limited to three-phase types). Operation:</li> </ol> <ol style="list-style-type: none"> <li>1. After identifying the issue using the above methods, reconnect correctly.</li> <li>2. After-sales support can use the LCD screen or EMS to view backend data for analysis, or record the data and send it to R&amp;D for analysis;</li> </ol>
E107	Meter or CT reverse connection	<p>Troubleshooting:</p> <ol style="list-style-type: none"> <li>1. Please check if the CT or meter CT signal wire connections are normal;</li> <li>2. Please check if the meter CT communication wire is normal;</li> <li>3. Please check if the CT or meter CT is connected in reverse;</li> <li>4. Please check if the CT or meter CT has tripped;</li> <li>5. Please check if the CT or meter CT is incorrectly connected (limited to three-phase types). Operation:</li> </ol> <ol style="list-style-type: none"> <li>1. After identifying the issue using the above methods, reconnect correctly.</li> <li>2. Or, reset the direction through the LCD screen or app (this method does not require reinstallation, only applicable for CT reverse connection; if a three-phase meter is used, this method supports only the case where all three phases are reversed, not individual phase correction).</li> <li>3. After-sales can use the LCD Screen or EMS to view and analyze back-end data, or record the data and send it to R&amp;D for analysis;</li> </ol>

E108	Grid Other Abnormalities	<p>1.If the anomaly is introduced due to external faults, the inverter automatically resumes normal operation once the fault disappears, without requiring human intervention.</p> <p>2.When the signal sampling circuit has an abnormality causing the DC component to be excessively high, this fault is a hardware issue that cannot be resolved through on-site troubleshooting and requires reporting to R&amp;D for handling;</p> <p>3.After-sales service can use the LCD screen or EMS to view backend data for analysis, or record the data and send it to R&amp;D for analysis;</p>
------	--------------------------	---

## b.Off-grid Side

Fault Code	Fault Name	Handling Method
E200	The Off-grid Output Voltage is Too High	Check the inverter settings to ensure that the output voltage is set within the correct range (off-grid voltage is not set, synchronous grid connection safety standard rated voltage, protection range is $\leq 160$ or $\geq 276$ ), try to increase the load or adjust the load distribution.
E201	The off-grid output voltage is too low	<p>1. Insufficient PV and battery power relative to load power, causing the inverter voltage to drop;</p> <p>2. Backup load power exceeds the inverter's maximum allowable output power;</p> <p>3. Reduce the Backup load or increase the capacity of the PV or battery side.</p>
E202	Off-grid output overload	Reduce the number of loads on the inverter's Backup side to ensure that the load power does not exceed the Backup's maximum output power.

## c.PV

Fault Code	Fault Name	Handling Method
E300	PV input overvoltage	<p>1. Check the series configuration of the corresponding photovoltaic array, ensuring that the open-circuit voltage of the array does not exceed the inverter's maximum operating voltage. After the array configuration is correct, the inverter alarm will automatically clear.</p> <p>2. If the open-circuit voltage of the PV string is normal and the alarm still exists, after-sales service can use the LCD screen or EMS to view the backend data for analysis, or record the data and send it to R&amp;D for analysis;</p>
E301	PV string-reverse	Check if the PV string is reversed
E302	PV overload	<p>1. Disconnect the AC output side switch and DC input side switch, then close the AC output side switch and DC input side switch after 5 minutes;</p> <p>2. If the fault still exists, after-sales service can use the LCD screen or EMS to view the backend data for analysis, or record the data and send it to R&amp;D for analysis;</p>

E303	AFCI fault	<ol style="list-style-type: none"> <li>Five faults occurring within one day will automatically recover; no action required. If immediate recovery is needed, you can manually clear the fault;</li> <li>Check if the CT connection on the AFCI board is normal;</li> <li>If arc faults occur frequently, after-sales service can use the LCD screen or EMS to view the backend data for analysis, or record the data and send it to R&amp;D for analysis;</li> </ol>
E304	Residual current High	<ol style="list-style-type: none"> <li>If it occurs occasionally, it may be due to occasional abnormalities in the external circuit. The fault will be cleared and normal operation will resume without the need for manual intervention.</li> <li>If it occurs frequently or cannot be restored for a long time, check the ground impedance of the PV string is too low or not.</li> </ol>
E305	PV Isolation Low	<ol style="list-style-type: none"> <li>Check the impedance between the PV string and the protective ground. If a short circuit occurs, correct the short circuit point.</li> <li>Check if the protective ground wire of the inverter is correctly connected.</li> <li>If it is confirmed that the impedance is indeed lower than the default value in rainy weather conditions, reset the "insulation resistance protection point" (default value is 50kΩ).</li> </ol>

#### d. Battery

Fault Code	Fault Name	Handling Method
E400	Battery BMS fault	<ol style="list-style-type: none"> <li>Restart the machine and observe whether the alarm still exists; (BMS hardware faults or any other faults not listed below)</li> <li>Determine the specific fault through the backend BMS main and sub fault codes, and perform related operations such as replacing the battery pack or BMS circuit board based on the specific fault type. If the specific fault type is identified, proceed with the relevant operations such as replacing the battery pack or BMS circuit board.</li> </ol>
E401	Battery BMS running abnormal	No action required, this is a normal indication during the battery charging and discharging process.
E402	Battery BMS communication	<ol style="list-style-type: none"> <li>Restart the machine and observe whether the alarm still exists;</li> <li>Contact the dealer/our company customer service center to arrange for maintenance personnel to investigate on-site the issue (harness connection problem).</li> </ol>
E403	Battery DCDC fault	<ol style="list-style-type: none"> <li>Restart the machine and observe whether the alarm still exists;</li> <li>Contact the dealer/our company customer service center to arrange for maintenance personnel to investigate the issue on-site</li> </ol>
E404	Battery DCDC run abnormal	<ol style="list-style-type: none"> <li>Restart the machine and observe whether the alarm still exists;</li> <li>Contact the dealer/our company customer service center to arrange for maintenance personnel to investigate the issue on-site</li> </ol>
E405	Battery output overload	<ol style="list-style-type: none"> <li>If it occurs occasionally, it may be due to short-term overload, which will automatically return to normal operation without the need for manual intervention;</li> <li>If it occurs frequently, reduce the load;</li> <li>If the load is within specifications and the fault still exists, then an extreme overcurrent fault has occurred. System Lock, please contact the dealer/our company customer service center.</li> </ol>

E406	Battery Over-voltage	<p>1.No manual intervention required; after discharging or resting, the battery total voltage can automatically recover if it falls below the fault recovery threshold.</p> <p>2. If the fault cannot be recovered, it indicates a battery extreme overvoltage fault, BMS system lock, requiring on-site manual confirmation of cell status. Based on the cell status, decide whether to clear the system lock fault and restart or replace the battery.</p>
E407	Battery Under-voltage	<p>1. After charging or resting, the battery voltage can automatically recover if it rises above the fault recovery threshold.</p> <p>2.If the fault cannot be recovered, it indicates a battery extreme undervoltage fault, BMS system lock, requiring on-site manual confirmation of cell status. Based on the cell status, decide whether to clear the system lock fault and restart or replace the battery.</p>
E408	Battery SOC is low	Charge the battery.
E409	Battery Over-temperature protection	<p>1.No manual intervention required, wait for the temperature to drop and then it will automatically recover (lead-acid batteries do not have a BMS and do not send temperature signals to the PCS)</p> <p>2. If the fault cannot be recovered, it is a battery extreme over-temperature fault, the system lock on the BMS, manual on-site confirmation of the cell status is required, and based on the cell status, decide to clear the system lock fault and restart or replace the battery</p>
E410	Battery Low-temperature protection	<p>1.No manual intervention required, wait for the BMS to start heating and the temperature to rise, then it will automatically recover (lead-acid batteries do not have a BMS and do not send temperature signals to the PCS)</p> <p>2. If the fault cannot be restored, it is a battery extreme low-temperature fault, and the BMS system is locked. On-site confirmation of the cell status is required, and based on the cell status, decide whether to clear the system lock fault and restart or replace the battery.</p>

### e.Diesel Generator

Fault Code	Fault Name	Handling Method
E500	Oil Machine Overload	<p>1. Stop the diesel generator operation, check if the wiring is properly connected. If the wiring is not properly connected, inspect the wiring and reconnect it.</p> <p>2. Confirm whether the output voltage, current, power, etc., parameters on the load side exceed the specified limits. If they do, reset the generator's rated power according to the requirements.</p> <p>3. If the wiring is intact and the parameter settings are within the specified limits but the fault still exists, please contact the dealer/our company customer service center. (After-sales need to provide the type and size of the load on-site and the generator's rated power, set rated power, or can also try reducing the load to observe if this fault occurs again)</p> <p>4. If the fault still exists, after-sales can use the LCD screen or EMS to view background data for analysis, or record the data and send it to R&amp;D for analysis;</p>

E501	Oil Machine Fault	<ol style="list-style-type: none"> <li>Restart the machine and observe whether the alarm still exists (abnormal generator voltage frequency, phase sequence error);</li> <li>Check if the generator wiring is normal, including: dry contact DO signal line, dry contact DI signal line, power line. Additionally, it is necessary to check that the generator has sufficient fuel and that the internal battery is functioning normally.</li> <li>Check if the actual voltage and frequency after the generator starts are correct (the normal voltage range is within <math>U_n \pm 30V</math>, the frequency is within <math>F_n \pm 7Hz</math>, where <math>U_n</math> is related to local safety regulations, such as 220V/230V/240V, and <math>F_n</math> is 50Hz/60Hz)</li> <li>Check if the generator supports signal start; if not, it needs to be started manually;</li> <li>If the fault still exists, after-sales can use the LCD screen or EMS to view backend data for analysis, or record the data and send it to R&amp;D for analysis;</li> </ol>
------	-------------------	---

## f.System

Fault Code	Fault Name	Handling Method
E600	Internal communication fault	<ol style="list-style-type: none"> <li>Restart the machine and observe whether the alarm still exists;</li> <li>Communication between the main DSP and the main ARM is interrupted for 10 seconds, then a fault is reported;</li> <li>Communication between the main DSP and the safety ARM is interrupted for 10 seconds, or the heartbeat packet is interrupted for 5 seconds, or the status is abnormal, then a fault is reported;</li> <li>After-sales service needs to handle issues based on the fault sub-code. If the reported fault is abnormal communication between the main DSP and main ARM, the cover should be opened to check if the wiring between them is loose, and reinsert or reseat the connection as necessary;</li> <li>If the fault still exists, after-sales service can use the LCD screen or EMS to view and analyze background data, or record the data and send it to R&amp;D for analysis;</li> </ol>
E601	PCS is running abnormally	<ol style="list-style-type: none"> <li>Possible causes of this fault: PV voltage is too high, inverter BUS voltage sampling is abnormal, power tube is damaged, etc;</li> <li>Restart the machine, observe whether the alarm still exists;</li> <li>Check if the PV voltage exceeds the voltage limit allowed by the model;</li> <li>Check if the wiring is normal;</li> <li>If the fault still exists, after-sales service can use the LCD screen or EMS to view and analyze background data, or record the data and send it to R&amp;D for analysis;</li> <li>If the fault still exists, please contact the dealer / our company customer service center.</li> </ol>
E602	PCS fault	<ol style="list-style-type: none"> <li>Possible causes of this fault: PV voltage is too high, inverter BUS voltage sampling is abnormal, power tube is damaged, etc;</li> <li>Restart the machine, observe whether the alarm still exists;</li> <li>Check if the PV voltage exceeds the voltage limit allowed by the model;</li> <li>Check if the wiring is normal;</li> <li>If the fault still exists, after-sales service can use the LCD screen or EMS to view and analyze background data, or record the data and send it to R&amp;D for analysis;</li> <li>If the fault still exists, please contact the dealer / our company customer service center.</li> </ol>

E603	OTA upgrade failure	<ol style="list-style-type: none"> <li>1. Check if the OTA update package is correct;</li> <li>2. Check if the conditions required for the OTA update are met, ensuring a stable power supply during the OTA process;</li> <li>3. Check if the network at the site is normal, ensuring that data can be received normally;</li> <li>4. Perform the OTA upgrade again;</li> <li>5. If the upgrade continues to fail, consider using a USB drive for the upgrade, or contact the dealer / our company customer service center;</li> </ol>
E604	Over-temperature protection	<ol style="list-style-type: none"> <li>1. Check if the ventilation at the inverter's installation location is good, if the fan exhaust is smooth, and if the ambient temperature is within the maximum allowable range.</li> <li>2. If the environment is not well-ventilated or the temperature is too high, improve the ventilation and cooling conditions.</li> <li>3. If the fault persists, the after-sales service can use the LCD screen or EMS to check the backend data for analysis, or record the data and send it to R&amp;D for analysis.</li> <li>4. If the fault persists, contact the dealer / our company customer service center.</li> </ol>
E605	Fan abnormal	<ol style="list-style-type: none"> <li>1. Restart the machine and observe whether the alarm still exists;</li> <li>2. Check if the fan is stalled;</li> <li>3. Check if the fan wiring is normal;</li> <li>4. If the fault still exists, after-sales can use the LCD screen or EMS to view background data for analysis, or record the data and send it to R&amp;D for analysis.</li> <li>5. If the fault persists, contact the dealer / our company customer service center.</li> </ol>
E606	Parallel machine abnormal	<ol style="list-style-type: none"> <li>1. Check if the communication lines between the parallel machines are making poor contact, and the fault will disappear automatically after the wiring is restored, without the need for manual intervention;</li> <li>2. Check if the software versions of all paralleled machines are consistent; if not, upgrade all machines to have the same program version;</li> <li>3. Check if the power wiring is normal, ensuring that the Backup outputs are connected together, and the AC input wirings are connected together. Ensure each phase is connected to the corresponding phase, strictly prohibiting incorrect phase connections;</li> <li>4. If the fault still exists, after-sales service can use the LCD screen or EMS to view the backend data for analysis, or record the data and send it to R&amp;D for analysis;</li> <li>5. If the fault still exists, please contact the dealer/our company customer service center.</li> </ol>

## 10 Packaging, transport, storage

- The entire machine is packaged using a combination of paper + EPE pearl cotton, and the internal PE bag has waterproof and dustproof functions.
- EPE pearl cotton foam pads are used in the middle to prevent damage to the system during handling and transport.
- Battery packs must be transported in accordance with UN3480 Dangerous Goods Transport and local laws and regulations.
- The system is heavy and must be handled mechanically.
- The equipment and packaging must not be sprayed with water and therefore must not be transported in the open air. Storage Temperature:
  - 20° C ~ 35° C, 12 months.
  - 20° C ~ 45° C, 3 months.
  - 20° C ~ 55° C, 1 month.(Keep SOC between 30% and 60% before storage)
- Storage humidity: 0% to 95% RH (non-condensing)
- Storage room should be ventilated, the room should be clean and dry, and should be dust and moisture proof.
- Storage time up to 3 months. It is recommended to charge and discharge the system for more than the specified time.
- Sunlight in the storage room should not shine directly on the system.

## Appendix 1 Table of PCS parameters(Europe)

Series Name				
	Powerinfi			
MODEL	MEI2-HS3H-AIO	MEI2-HS3.68H-AIO	MEI2-HS3.8H-AIO	MEI2-HS4H-AIO
PV Input				
Max. Input Voltage	550 d.c.V			
MPPT Voltage Range	80 - 500 d.c.V			
Max. Input Current	20/20 d.c.A			
I <sub>sc</sub> PV (absolute maximum)	25/25 d.c.A			
Battery Data				
Battery Type	LiFePO4 (LFP)			
Battery Voltage Range	320 - 480 Vd.c.			
Rated Charge / Discharge Current	10.0/7.9 d.c.A	10.0/9.6 d.c.A	10.0/10.0 d.c.A	10.0/10.5 d.c.A
Max. Charge / Discharge Current	12.5/10.5 d.c.A	12.5/11.7 d.c.A	12.5/13.3 d.c.A	12.5/14.0 d.c.A
AC Grid Side(On-Grid)				
Rated Output Power	3000 W	3680 W	3800 W	4000 W
Max. Output Power	3300 W	3680 W	4180 W	4400 W
Rated Output Apparent Power	3000 VA	3680 VA	3800 VA	4000 VA
Max. Output Apparent Power	3300 VA	3680 VA	4180 VA	4400 VA
Rated Input / Output Current (@220V)	13.7/13.7 a.c.A	16.8/16.8 a.c.A	17.3/17.3 a.c.A	18.2/18.2 a.c.A
Rated Input / Output Current (@230V)	13.1/13.1 a.c.A	16.0/16.0 a.c.A	16.6/16.6 a.c.A	17.4/17.4 a.c.A
Max. Input / Output Current	27.3/15.0 a.c.A	33.5/16.8 a.c.A	34.6/19.0 a.c.A	36.4/20.0 a.c.A
Max. Output Fault Current (Peak and Duration)	43@10ms	51@10ms	54@10ms	57@10ms
Inrush Current (Peak and Duration)	170@2μs			
Nominal Frequency	50/60 Hz			
Nominal Input / Output Voltage	L/N/PE, 220/230 a.c.V			
Backup Port				
Max. Output Apparent Power	3300 VA	3680 VA	4180 VA	4400 VA
Rated Output Current (@220V)	13.7 a.c.A	16.8 a.c.A	17.3 a.c.A	18.2 a.c.A
Rated Output Current (@230V)	13.1 a.c.A	16.0 a.c.A	16.6 a.c.A	17.4 a.c.A
Max. Output Current	15.0 a.c.A	16.8 a.c.A	19.0 a.c.A	20.0 a.c.A
Max. Output Fault Current (Peak and Duration)	43@10ms	51@10ms	54@10ms	57@10ms
Inrush Current (Peak and Duration)	170@2μs			
Nominal Output Voltage	L/N/PE, 220/230 a.c.V			
Nominal Frequency	50/60 Hz			
Others				
Operating Temperature Range	-20°C to +60°C			
Ingress Protection	IP66			
Protective Class	I			
Overvoltage Category	III (AC), II (DC)			
Inverter Topology	Non-isolated			
AC Side Power Factor	~1 (-0.8leading ... 0.8lagging)			

MODEL					
	MEI2-HS4.6H-AIO	MEI2-HS5H-AIO	MEI2-HS5H-AIO2	MEI2-HS6H-AIO	MEI2-HS8H-AIO
<b>PV Input</b>					
Max. Input Voltage	550 d.c.V				
MPPT Voltage Range	80 - 500 d.c.V				
Max. Input Current	20/20 d.c.A				20/ 20/20 d.c.A
I <sub>sc</sub> PV (absolute maximum)	25/25 d.c.A				25/25/25 d.c.A
<b>Battery Data</b>					
Battery Type	LiFePO4 (LFP)				
Battery Voltage Range	320 - 480 Vd.c.				
Rated Charge / Discharge Current	15.0/12.1 d.c.A	15.0/13.1 d.c.A	15.0/13.1 d.c.A	15.0/15.7 d.c.A	20.0/21.0 d.c.A
Max. Charge / Discharge Current	18.7/15.8 d.c.A	18.7/17.4 d.c.A	18.7/15.8 d.c.A	18.7/21.0 d.c.A	25.0/25.0 d.c.A
<b>AC Grid Side(On-Grid)</b>					
Rated Output Power	4600 W	5000 W	5000 W	6000 W	8000 W
Max. Output Power	5000 W	5500 W	5000 W	6600 W	8000 W
Rated Output Apparent Power	4600 VA	5000 VA	5000 VA	6000 VA	8000 VA
Max. Output Apparent Power	5000 VA	5500 VA	5000 VA	6600 VA	8000 VA
Rated Input / Output Current (@220V)	21.0/21.0 a.c.A	22.8/22.8 a.c.A	22.8/22.8 a.c.A	27.3/27.3 a.c.A	36.4/36.4 a.c.A
Rated Input / Output Current (@230V)	20.0/20.0 a.c.A	21.8/21.8 a.c.A	21.8/21.8 a.c.A	26.1/26.1 a.c.A	34.8/34.8 a.c.A
Max. Input / Output Current	41.9/22.8 a.c.A	45.5/25.0 a.c.A	45.5/22.8 a.c.A	50.0/30.0 a.c.A	50.0/36.4 a.c.A
Max. Output Fault Current (Peak and Duration)	65@10ms	71@10ms	71@10ms	85@10ms	85@10ms
Inrush Current (Peak and Duration)	170@2μs				
Nominal Frequency	50/60 Hz				
Nominal Input / Output Voltage	L/N/PE, 220/230 a.c.V				
<b>Backup Port</b>					
Max. Output Apparent Power	5000 VA	5500 VA	5000 VA	6000 VA	8000 VA
Rated Output Current (@220V)	21.0 a.c.A	22.8 a.c.A	22.8 a.c.A	27.3 a.c.A	34.8 a.c.A
Rated Output Current (@230V)	20.0 a.c.A	21.8 a.c.A	21.8 a.c.A	26.1 a.c.A	36.4 a.c.A
Max. Output Current	22.8 a.c.A	25.0 a.c.A	22.8 a.c.A	30.0 a.c.A	36.4 a.c.A
Max. Output Fault Current (Peak and Duration)	65@10ms	71@10ms	71@10ms	85@10ms	85@10ms
Inrush Current (Peak and Duration)	170@2μs				
Nominal Output Voltage	L/N/PE, 220/230 a.c.V				
Nominal Frequency	50/60 Hz				
<b>Others</b>					
Operating Temperature Range	-20°C to +60°C				
Ingress Protection	IP66				
Protective Class	I				
Overvoltage Category	III (AC), II (DC)				
Inverter Topology	Non-isolated				
AC Side Power Factor	~1 (-0.8leading ... 0.8lagging)				

## Appendix 2 Table of PCS parameters(Australia)

Series Name				
	Powerinfi			
MODEL				
	MEI2-HS3H-AI01	MEI2-HS3.68H-AI01	MEI2-HS3.8H-AI01	MEI2-HS4H-AI01
PV Input				
Max. Input Voltage	550 d.c.V			
MPPT Voltage Range	80 - 500 d.c.V			
Max. Input Current	20/20 d.c.A			
In the solar 40°C / 60°C	20A			
I <sub>sc</sub> PV (absolute maximum)	25/25 d.c.A			
Battery Data				
Battery Type	LiFePO4 (LFP)			
Battery Voltage Range	320 - 480 d.c.V			
Rated Charge / Discharge Current	10.0/7.9 d.c.A	10.0/9.6 d.c.A	10.0/10.0 d.c.A	10.0/10.5 d.c.A
Max. Charge / Discharge Current	12.5/9.5 d.c.A	12.5/11.7 d.c.A	12.5/12.1 d.c.A	12.5/12.7 d.c.A
AC Grid Side(On-Grid)				
Rated Output Power	3000 W	3680 W	3800 W	4000 W
Max. Output Power	3000 W	3680 W	3800 W	4000 W
Rated Output Apparent Power	3000 VA	3680 VA	3800 VA	4000 VA
Max. Output Apparent Power	3000 VA	3680 VA	3800 VA	4000 VA
Rated Input / Output current	13.1/13.1 a.c.A	16.0/16.0 a.c.A	16.6/16.6 a.c.A	17.4/17.4 a.c.A
Max. Input / Output Current	26.1/13.1 a.c.A	32.0/16.0 a.c.A	33.1/16.6 a.c.A	34.8/17.4 a.c.A
Max. Output Fault Current (Peak and Duration)	43@10ms	51@10ms	54@10ms	57@10ms
Inrush Current (Peak and Duration)	170@2μs			
Nominal Input / Output Voltage	L/N/PE, 230 a.c.V			
Nominal Frequency	50/60 Hz			
Backup Port				
Rated / Max. Output Apparent Power	3000 VA	3680 VA	3800 VA	4000 VA
Rated Output Current	13.1 a.c.A	16.0 a.c.A	16.6 a.c.A	17.4 a.c.A
Max. Output Current	13.1 a.c.A	16.0 a.c.A	16.6 a.c.A	17.4 a.c.A
Max. Output Fault Current (Peak and Duration)	43@10ms	51@10ms	54@10ms	57@10ms
Inrush Current (Peak and Duration)	170@2μs			
Nominal Output Voltage	L/N/PE, 230 a.c.V			
Nominal Frequency	50/60 Hz			
Others				
Operating Temperature Range	-20°C to +60°C			
Ingress Protection	IP66			
Protective Class	I			
Overvoltage Category	III (AC), II (DC)			
Inverter Topology	Non-isolated			
AC Side Power Factor	~1 (-0.8leading ... 0.8lagging)			

## Appendix 2 Table of PCS parameters(Australia)

MODEL				
	MEI2-HS4.6H-AIO1	MEI2-HS5H-AIO1	MEI2-HS6H-AIO1	MEI2-HS8H-AIO1
<b>PV Input</b>				
Max. Input Voltage			550 d.c.V	550 d.c.V
MPPT Voltage Range			80 - 500 d.c.V	80 - 500 d.c.V
Max. Input Current			20/20 d.c.A	20/20/20 d.c.A
I <sub>line solar</sub> 40°C / 60°C			20A	20A
I <sub>sc</sub> PV (absolute maximum)			25/25 d.c.A	25/25/25 d.c.A
<b>Battery Data</b>				
Battery Type	LiFePO4 (LFP)			
Battery Voltage Range	320 - 480 d.c.V			
Rated Charge / Discharge Current	15.0/12.1 d.c.A	15.0/13.1 d.c.A	15.0/15.7 d.c.A	20.0/21.0 d.c.A
Max. Charge / Discharge Current	18.7/14.6 d.c.A	18.7/15.9 d.c.A	18.7/19.1 d.c.A	25.0/25.0 d.c.A
<b>AC Grid Side(On-Grid)</b>				
Rated Output Power	4600 W	5000 W	6000 W	8000 W
Max. Output Power	4600 W	5000 W	6000 W	8000 W
Rated Output Apparent Power	4600 VA	5000 VA	6000 VA	8000 VA
Max. Output Apparent Power	4600 VA	5000 VA	6000 VA	8000 VA
Rated Input / Output current	20.0/20.0 a.c.A	21.8/21.8 a.c.A	26.1/26.1 a.c.A	34.8/34.8 a.c.A
Max. Input / Output Current	40.0/20.0 a.c.A	43.5/21.8 a.c.A	50.0/26.1 a.c.A	50.0/34.8 a.c.A
Max. Output Fault Current (Peak and Duration)	65@10ms	71@10ms	85@10ms	85@10ms
Inrush Current (Peak and Duration)	170@2μs			
Nominal Input / Output Voltage	L/N/PE, 230 a.c.V			
Nominal Frequency	50/60 Hz			
<b>Backup Port</b>				
Rated / Max. Output Apparent Power	4600 VA	5000 VA	6000 VA	8000 VA
Rated Output Current	20.0 a.c.A	21.8 a.c.A	26.1 a.c.A	34.8 a.c.A
Max. Output Current	20.0 a.c.A	21.8 a.c.A	26.1 a.c.A	34.8 a.c.A
Max. Output Fault Current (Peak and Duration)	65@10ms	71@10ms	85@10ms	85@10ms
Inrush Current (Peak and Duration)	170@2μs			
Nominal Output Voltage	L/N/PE, 230 a.c.V			
Nominal Frequency	50/60 Hz			
<b>Others</b>				
Operating Temperature Range	-20°C to +60°C			
Ingress Protection	IP66			
Protective Class	I			
Overvoltage Category	III (AC), II (DC)			
Inverter Topology	Non-isolated			
AC Side Power Factor	~1 (-0.8leading ... 0.8lagging)			

## Appendix 3 Battery Pack Parameter

Model	MH-BAT5.0-HPE
Battery Type	LiFePO <sub>4</sub> (LFP)
Battery Designation	IFpP51/161/119[16S]E/-20+50/95
Rated Capacity	100Ah
Nominal Voltage (Battery)	51.2 Vd.c.
Nominal Voltage (System)	410 Vd.c.
Rated Energy	5.12kWh
Operating Voltage Range (System)	362 – 464 Vd.c.
Max input/output Power (System)	2.5kW
Nominal input/output Current (System)	6.1 Ad.c.
Max input/output Current (System)	6.9 Ad.c.
Protective Class	Class I
Ingress Protection	IP66
Discharging Temperature Range	-20°C to +50°C
Charging Temperature Range	-20°C to +50°C
Weight	50 kg

## **Hiconics Eco-energy Drive Technology Co., Ltd.**

No.3 Boxing 2nd Road, Economic and Technological Development Zone,  
100176, Beijing, P.R. China

**European :**

Email: [solar\\_service\\_eu@midea.com](mailto:solar_service_eu@midea.com)

**Australian :**

Email: [solar\\_service\\_au@midea.com](mailto:solar_service_au@midea.com) Tet: +61 1300 457 098

**Global:**

Email: [solar\\_service@midea.com](mailto:solar_service@midea.com)

Web: [www.hiconics-global.com](http://www.hiconics-global.com)

**MADE IN CHINA**